

May 24, 1927.

J. M. BROWNING

1,629,652

CARTRIDGE FEEDING MECHANISM FOR AUTOMATIC FIREARMS

Filed July 8, 1925

2 Sheets-Sheet 1

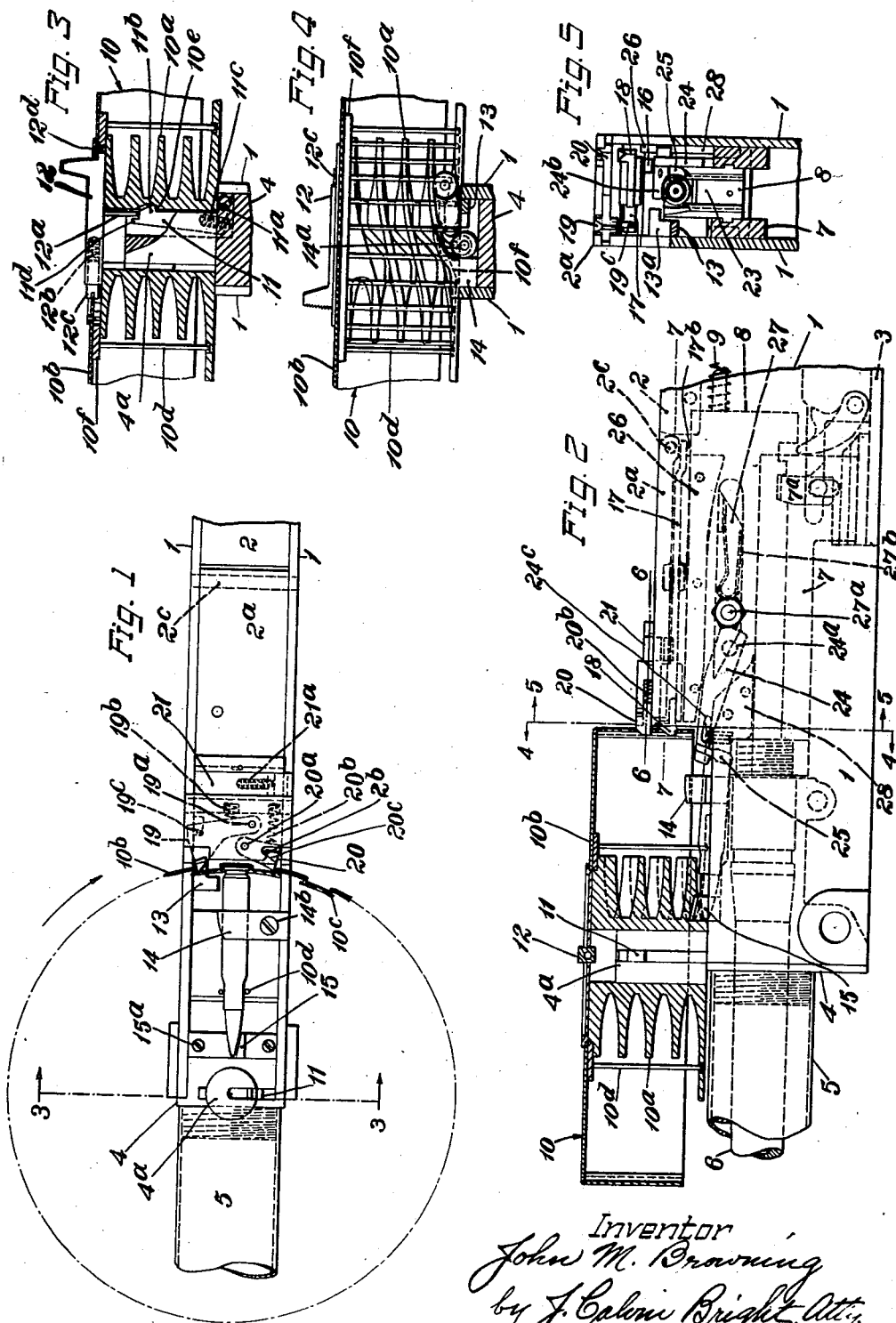

Inventor  
John M. Browning  
by J. Calvin Bright, Att'y.

May 24, 1927.

1,629,652

J. M. BROWNING

CARTRIDGE FEEDING MECHANISM FOR AUTOMATIC FIREARMS

Filed July 8, 1925

2 Sheets-Sheet 2

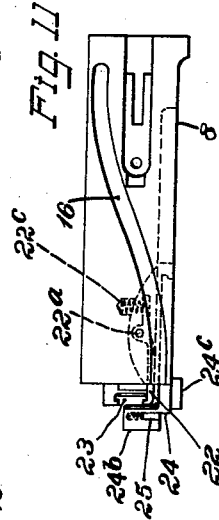
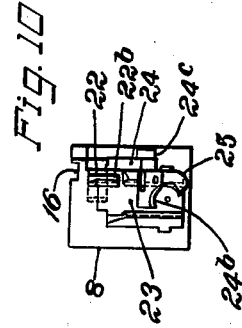
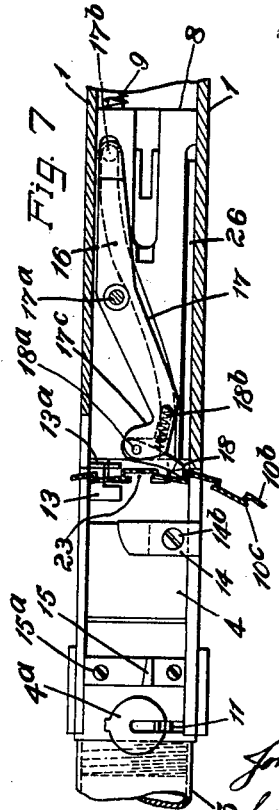
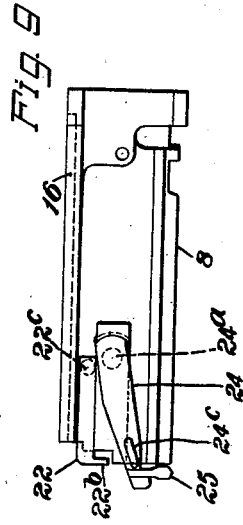
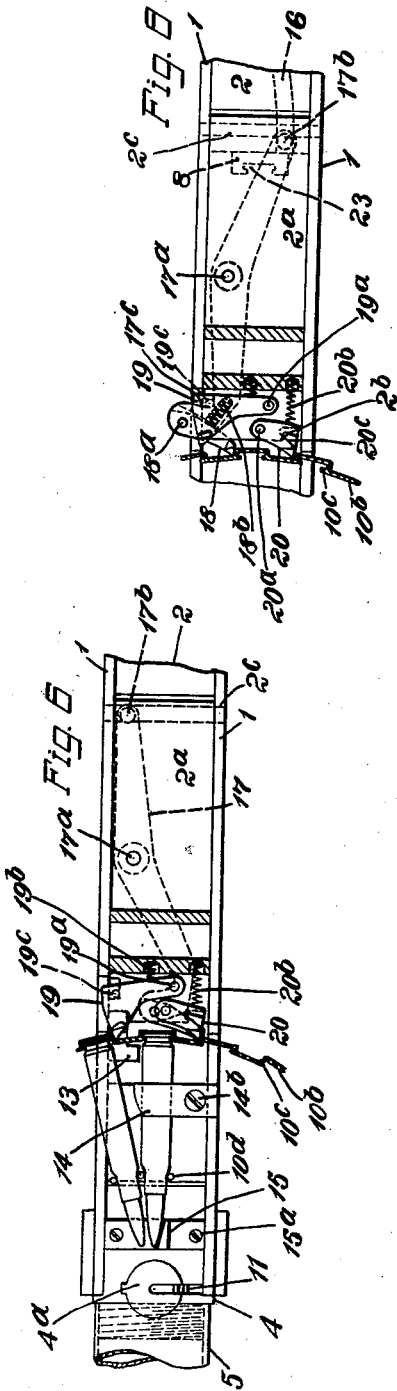

Inventor  
John M. Browning  
by J. Cahini, Bright, Atty.

# UNITED STATES PATENT OFFICE.

JOHN M. BROWNING, OF OGDEN, UTAH; JOHN BROWNING ADMINISTRATOR OF SAID  
JOHN M. BROWNING, DECEASED.

## CARTRIDGE-FEEDING MECHANISM FOR AUTOMATIC FIREARMS.

Application filed July 8, 1925. Serial No. 42,301.

The invention relates generally to cartridge feeding mechanisms for automatic firearms and more particularly to such feeding mechanisms involving the use of a cartridge magazine of the rotary drum type.

The main object of the invention consists in the provision of this type of feed in an automatic firearm of the recoil-operated class, such as is shown, for example, in the Letters Patent of the United States, No. 1,293,021 granted to me on February 4, 1919, for automatic machine gun. Said class of automatic firearm has heretofore usually been provided with a feeding arrangement whereby the cartridges are supplied to the arm in the operation thereof by means of a flexible belt.

Under certain conditions of operation, as for example, when a gun is flexibly mounted so as to give it a wide range of movement or in installations where two guns are fixedly mounted on opposite sides of an airplane fuselage in position to fire through the plane swept by the blades of the airplane propeller, the rotary drum type of feed is more desirable than the belt feed, because it avoids, in the case of a flexibly mounted gun, the provision of a belt container movable with the gun or of special guiding means from the belt container to the feed channel on the gun or both, and, in the case of the fixedly mounted guns, it avoids the necessity of providing for this purpose, either both right- and left-hand fed guns or guns which have a feeding mechanism reversible, at will, for either right or left-hand feed.

While a main object of my invention is to provide the rotary drum type of feed in a firearm of the class shown in my prior patent, certain features of my invention are equally applicable to other types of automatic firearms.

Other and further objects and advantages will appear from the following disclosure. The preferred form of the invention is shown in the drawings in which:

Fig. 1 represents, in a partial top plan view, a Browning air-cooled machine gun with the invention applied thereto; the magazine is shown more or less diagrammatically, part of the drum being shown in section, and the central fixed part of the maga-

zine being omitted. A cartridge is shown in position for rearward removal from beneath the magazine drum.

Fig. 2 represents, in a side elevation, the portion of the gun shown in Fig. 1, the magazine being shown in a central vertical longitudinal section and parts of the mechanism within the breech casing being indicated by dotted lines.

Fig. 3 represents a front view of a partial vertical transverse section on the line 3—3 of Fig. 1 showing a means for releasably securing the magazine on the gun.

Fig. 4 represents a rear view of a partial vertical transverse section through the gun taken on the line 4—4 of Fig. 2, the rear and side portions of the magazine drum being broken away; this figure shows the relative positions of the foremost cartridge in the magazine and the cartridge fed therefrom into position for rearward removal.

Fig. 5 represents a front view of a partial vertical transverse section through the gun casing and the barrel extension taken on the line 5—5 of Fig. 2; the breech block and parts of the cartridge feeding mechanism are shown in elevation.

Fig. 6 represents a top plan view of a partial horizontal section through the breech casing and the magazine drum on the line 6—6 of Fig. 2; the relative positions of the cartridge ready for rearward removal and of the foremost cartridge in the magazine are clearly shown in this figure.

Fig. 7 represents a view similar to Fig. 6, the section being taken on a lower plane, as represented by the line 7—7 of Fig. 2, and the cartridges being omitted.

Fig. 8 represents a view similar to Fig. 6, the section being taken on the same plane, but parts of the feeding mechanism being shown in different positions.

Figs. 9, 10 and 11 represent the breech block and parts mounted thereon, respectively, in a left hand side view, in a front view and in a top plan view.

The machine gun to which the invention is shown applied comprises, as usual, a frame or breech casing having the general shape of a rectangular box formed by side plates 1, 1, a fixed top plate 2 at the rear portion and a movable top cover 2<sup>a</sup> at the forward portion, a fixed bottom plate 3, a rear plate (not

shown) and a trunnion block 4 closing the front of the casing. To a threaded forward extension of the trunnion block is secured the usual barrel casing 5, see Figs. 1 and 2.

5 The barrel 6 and barrel extension 7 are supported and guided for limited longitudinal movement in the trunnion block 4 and portions of the casing in rear thereof in a usual manner. The breech block 8 is  
10 guided for longitudinal reciprocating movement in said barrel extension and, when the parts are in forward firing position, it is locked to the barrel and barrel extension by a transversely movable locking block 7<sup>a</sup> on  
15 the barrel extension 7. After the firing of a shot, the barrel, barrel extension and breech block recoil together a short distance, in which movement the breech block is un-  
20 locked and is then thrown rearwardly against the tension of a reaction spring 9, Figs. 2 and 7, which, together with a buffer on the rear plate (not shown) and an additional spring (not shown) acting on the bar-  
25 rel and barrel extension, which are held in a rearward position until the breech block has passed through the greater portion of its forward stroke, returns said breech block, barrel and barrel extension to their forward  
30 firing positions, in which return the breech block is again locked to the barrel and barrel extension, all in a usual manner as fully disclosed in the prior patent above referred to.

In the rearward and forward movements  
35 of the breech block a cartridge is transferred from a position above the barrel into the chamber of the barrel, and the empty shell in the barrel chamber is extracted and ejected downwardly through an opening in the  
40 bottom of the breech casing.

By the present invention the type of gun disclosed in my prior patent hereinbefore referred to is modified in a number of important respects to provide a construction where-  
45 by the cartridges may be successively brought into the position above the barrel by the use of a rotary drum magazine, and transferred from said position into the barrel chamber.

50 In order that the rotary drum magazine, designated generally by the numeral 10, may be brought as near as possible to the horizontal plane through the barrel axis and thereby facilitate the feeding of the car-  
55 tridges from the magazine into a position for rearward removal, the front portion of the side plates 1, 1 of the breech casing, and the trunnion block 4 are made of reduced height. At its forward portion the trunnion  
60 block 4 is provided with a vertical post 4<sup>a</sup> to receive the magazine 10. Rearwardly of said post the top of the block is formed with a seat inclining slightly in rearward and downward direction, as shown in Fig. 2,  
65 upon which a cartridge is adapted to rest

prior to its rearward removal in the manner to be described later on.

The magazine comprises the usual stationary central member 10<sup>a</sup> and the rotary member or drum 10<sup>b</sup>. The stationary member 10<sup>a</sup> has a height dependent upon the number of cartridges the magazine is designed to hold and is provided with a continuous guide way for the bullet ends of the  
70 cartridges, which guide way opens downwardly into the discharge opening through which the cartridges pass from the magazine. The stationary member has a central opening which fits over the post 4<sup>a</sup>, the proper location of the discharge opening and  
75 the non-rotation of the member 10<sup>a</sup> on the post being assured by a rib on the post, which co-operates, for this purpose, with a corresponding groove in the member 10<sup>a</sup>. The rotary drum 10<sup>b</sup> has its outer cylindrical  
80 portion corrugated in a usual manner to provide vertical guiding grooves, on the inside thereof, for the heads of the cartridges, the heads being retained in said guiding grooves by any suitable means, as the flanges  
85 10<sup>c</sup> engaging the grooves forward of the heads of the cartridges, see Figs. 1, 6, 7 and 8. Adjacent the periphery of the fixed central member 10<sup>a</sup> additional vertical spacing means, such as the pins 10<sup>d</sup> secured to the  
90 top of the rotary drum, are provided between the vertical rows of cartridges.

By this construction, the cartridges in the magazine are advanced toward and successively moved through the discharge opening  
100 in the stationary member 10<sup>a</sup> of the magazine in the rotary movement of the drum. In the embodiment of the invention shown in the drawings, inclined portions of the guideway in the member 10<sup>a</sup> are inclined in  
105 a direction, whereby the cartridges are discharged from the magazine by rotating the drum 10<sup>b</sup> in a clockwise direction, as indicated by the arrow in Fig. 1.

To lock the magazine on the gun, any suitable means may be provided. As shown in  
110 Fig. 3, such means may comprise a latch 11 pivoted at 11<sup>a</sup> in a recess in the trunnion block 4, and having an upwardly extending portion provided with a locking projection  
115 11<sup>b</sup> adapted to co-operate, for this purpose, with a shoulder 10<sup>e</sup> on the stationary member 10<sup>a</sup> of the magazine. The projection 11<sup>b</sup> is bevelled at the top to allow it to be cammed back, when the magazine is placed  
120 on the gun, against the tension of the latch spring 11<sup>c</sup> seated in a recess in the latch and bearing at one end against the trunnion block.

In order to release the latch 11 when it is  
125 desired to remove the magazine 10 from the gun, a slidably mounted element 12 is provided on the top of the stationary member 10<sup>a</sup> of the magazine. This element 12 is actuated in one direction by a spring 12<sup>b</sup> 130

seated in a recess in said element and having one end thereof bearing against a plunger 12<sup>c</sup> extending into said recess and supported at its outer end by an abutment on the stationary member 10<sup>a</sup> of the magazine. The slidable element 12 has a downward projection 12<sup>a</sup> adapted to co-operate with a shoulder 11<sup>d</sup> on the latch 11. The element 12 also serves to yieldingly oppose relative rotation of the members 10<sup>a</sup> and 10<sup>b</sup> by the engagement of its rounded or V-shaped nose 12<sup>d</sup> into corresponding spaced notches formed in the reinforced portion 10<sup>c</sup> of the rotary drum 10<sup>b</sup> surrounding the central opening therein, see Fig. 3, thereby providing a frictional lock to prevent relative rotation of the members when the magazine is off the gun but not appreciably affecting the rotation of the drum by the mechanism to be hereinafter described when the magazine is on the gun. Sufficient lost motion is provided between the downward projection 12<sup>a</sup> on the slidable element 12 and the co-operating shoulder 11<sup>d</sup> on the latch 11 to prevent the actuation of the latch in the rotation of the magazine drum by said mechanism.

By this construction the magazine can be readily removed from the gun with one hand by first pressing the slidable element 12 back against the action of its spring 12<sup>b</sup> with the thumb of the hand grasping the magazine drum, and then lifting the magazine off the post 4<sup>a</sup>.

To permit the mounting of the magazine 10 as near as possible to the horizontal plane passing through axis of the barrel and yet allow the rearward removal of the cartridge positioned centrally on the trunnion block, as shown in Figs. 1, 2 and 6, the outer cylindrical portion of the drum 10<sup>b</sup> is made of less height than the stationary member 10<sup>a</sup> of the magazine, see Figs. 2, 3 and 4. From this it results that the cartridges in the lowest tier project for a distance approximately equal to one half their diameters below the cylindrical portion of the drum 10<sup>b</sup> and, to prevent the premature passing of the heads of the cartridges in said tier from the guideways provided therefor on said cylindrical portion of the drum, the lower flange of the guideway on the fixed member 10<sup>a</sup> for said lowest tier of cartridges is extended outwardly, as clearly shown in Fig. 2, toward the heads of the cartridges a distance sufficient to prevent any appreciable downward tipping of the heads of said tier cartridges.

The vertical spacing pins 10<sup>a</sup> on the rotary drum 10<sup>b</sup>, on the other hand, do extend downward as near to the bottom of the fixed member 10<sup>a</sup> as may be, and to provide clearance for the lower ends of these pins, the outwardly extended flange at the bottom of the fixed member 10<sup>a</sup> is preferably formed with an annular groove, as is clearly shown in Figs. 2, 3 and 4.

This construction permits the pins 10<sup>a</sup>, in co-operation with the guiding and holding means now to be described, to perform the important function, in the rotary movement of the drum, of moving the foremost cartridge in the magazine into the central position in which a cartridge is shown in Figs. 1, 2 and 6, and of holding said cartridge in this position until the same is rearwardly removed.

The forward edge of the discharge opening of the magazine 10 is so arranged relative to the breech casing of the gun that the foremost cartridge in the magazine is free to pass downwardly from the magazine, as soon as the head of the cartridge has been moved, in the rotation of the drum, inwardly slightly beyond the position of said cartridge, as shown in Fig. 4. At substantially this same position in the movement of the drum the forward end of the cartridge is brought into engagement with the downwardly and inwardly inclined surface 10<sup>c</sup>, see Fig. 4, on the stationary member 10<sup>a</sup> of the magazine to start the cartridge downwardly. If the gun is upright this downward movement will also be assisted by gravity. To prevent the head end of the cartridge from dropping down to its lowest position as soon as, in the rotation of the drum, the cartridge passes inwardly beyond the forward edge of the discharge opening, a small horizontal shelf 13, see Figs. 5, 6 and 7, is provided, this shelf extending inward some distance from the right hand side plate 1, of the breech casing. To prevent premature rearward movement of a cartridge whose head has been lowered below the cylindrical portion of the drum 10<sup>b</sup>, said shelf is preferably provided with a vertical rear wall 13<sup>a</sup> of sufficient height and extending inward from the side plate a sufficient distance, see Figs. 5 and 7, to effectually prevent such movement until the cartridge has been moved inwardly into the central position shown in Figs. 1, 2 and 6.

When the cartridge has been moved inwardly, in the rotation of the drum 10<sup>b</sup>, until the cartridge head can pass off the shelf 13, the top surface of said cartridge is brought into engagement with a downwardly and inwardly inclined surface 14<sup>a</sup> provided on the combined cartridge guide and stop 14 which is secured in any suitable manner to the trunnion block 4 as by means of a screw 14<sup>b</sup>, see Figs. 1, 2, 4, 6 and 7.

The cartridge is, in the further rotation of the magazine drum, now positively cammed down at the front and at the rear, because it is forced into engagement with the fixed cam surfaces 10<sup>c</sup> and 14<sup>a</sup>, until it is brought into engagement with the substantially vertical faces of the rear and front cartridge stops 14 and 15. The front stop 15 is shown projecting upwardly from the

trunnion block adjacent the post 4<sup>a</sup> and the stop surface thereon is shown inclined rearwardly and inwardly to conform to the taper of the projectiles, see Figs. 1, 6 and 7. This stop 15 is preferably formed, as shown, on a separate piece secured in a recess in the top of the trunnion block as by the screws 15<sup>a</sup>.

It will be seen that, by this construction, the foremost cartridge in the magazine is positively brought by the co-operation of the cam surfaces 10<sup>i</sup> and 14<sup>a</sup> and the spacing and driving pin 10<sup>d</sup> in engagement with said cartridge, into a position centrally above the barrel and inclining slightly rearwardly and downwardly so as to permit it to be readily rearwardly removed, and after having been brought into this position as shown in Figs. 1, 2 and 6, it is held therein by the cartridge stops 14 and 15 engaging it, respectively, at the rear and at the front on one side thereof, and the said spacing pin 10<sup>d</sup> engaging the opposite side thereof at an intermediate point.

It will be evident that this provides an exceedingly simple yet highly efficient and reliable construction for removing a cartridge from the magazine and transferring it into position for rearward removal without the use of any movable parts other than the magazine drum 10<sup>b</sup> and the mechanism for driving it step by step, which will now be described.

For rotating the drum of the magazine stepwise in the operation of the gun, mechanism actuated by the reciprocating movement of a recoiling member of the gun is provided. This recoiling member is preferably the breech block because of its long stroke and its weight. To this end, the breech block is provided in its top surface with a cam groove 16, the approximate shape of which is clearly shown in Figs. 7 and 11. A feed lever 17 having two arms of approximately equal lengths is pivoted on the under side of the movable top cover 2<sup>a</sup> of the breech casing on a pivot pin 17<sup>a</sup> and has at the end of its rear arm a downwardly projecting stud 17<sup>b</sup> which extends into the cam groove 16 on the breech block. The forward arm of the feed lever extends to a point adjacent the periphery of the drum 10<sup>b</sup> of the magazine and has a laterally offset portion at its end. This end of the arm is provided with a horizontal slot in which the feed pawl 18 is pivoted on the pin 18<sup>a</sup>. A spring 18<sup>b</sup>, Figs. 7 and 8, seated in a recess on the lever arm, moves the pawl to its operative position.

As hereinbefore stated, the cylindrical portion of the magazine drum 10<sup>b</sup> is corrugated, and these corrugations form opposed series of equally spaced shoulders on the periphery thereof. The point of the feed pawl 18 is in a position to cooperate with one of these series of shoulders, so that on

each rearward and forward movement of the breech block, the magazine drum 10<sup>b</sup> is rotated one step.

By reference to Figs. 7 and 8 the action of the feed mechanism just described will be evident. In Fig. 7 the feed lever and feed pawl are shown at the end of a feeding stroke, or at the beginning of an idle stroke, and the breech block is in its forward firing position. In Fig. 8 the feed lever and pawl are shown at the beginning of a feeding stroke, or at the end of an idle stroke, and the breech block is in its rearward position. It will be understood, as most clearly shown in Figs. 5 and 7, that the right hand side plate 1 of the breech casing is cut away to provide the necessary clearance for the forward end of the feed lever and the feed pawl when moved to the position shown in Fig. 8. By the construction shown, the feeding stroke occurs during the forward or return movement of the breech block, which is desirable because the forward movement of the breech block is less violent than the rearward movement thereof after the firing of a shot, and it is necessary, to prevent excessive strain on the parts, that the full drum, which has considerable inertia, be started from a position of rest gradually. This condition is attained by the shape of the cam in the breech block and by the less violent return of the breech block under the action of its reaction spring 9 and the buffer (not shown).

It has also been found desirable that a positive stop be provided to bring the drum to rest at the end of each feeding stroke. This is particularly desirable when the magazine is almost empty with only one or several cartridges remaining therein, for if no other stopping means were provided, the momentum of the drum would have to be taken up at the end of the feeding stroke by just one or two spacing pins 10<sup>a</sup> and such pin or pins might, under these conditions, be bent or broken so as to render the magazine unfit for further use without correcting the injury thereto. To this end a stop pawl 19 is provided, this pawl being adapted to co-operate with the series of shoulders on the drum opposed to the series engaged by the feed pawl 18. This stop pawl, as clearly shown in Figs. 1, 5, 6 and 8, is mounted to swing, in a horizontal slot formed in the forward vertically thickened portion of the top cover 2<sup>a</sup> of the breech casing, on the pivot pin 19<sup>a</sup>. It is moved to its operative position with the nose thereof in engagement with the periphery of the drum by the spring 19<sup>b</sup>, see Fig. 6.

In order to move the stop pawl 19 to its inoperative position and to hold it in said position during the first portion of the feeding stroke of the feed lever 17 and feed pawl 18, cooperating means are provided on said feed

lever and stop pawl. Such means may comprise a downward projection 19<sup>c</sup> near the free end of the stop pawl 19 which passes through a slot in the portion of the top cover below said stop pawl and extends into the path of movement of the feed lever. The rear surface of the laterally offset portion on the front end of the feed lever provides a cam surface 17<sup>c</sup> for cooperation with said downward projection 19<sup>c</sup> whereby the stop pawl is moved to its inoperative position, shown in Fig. 8, in the idle stroke of the feed lever, and is kept in said position during the first portion of the feeding stroke of said lever, but is released before the feed lever completes its feeding stroke, to allow the spring 19<sup>b</sup> to return to its operative position with its nose in front of the succeeding stop shoulder on the magazine drum. The downward projection 19<sup>c</sup> on the stop pawl also serves to limit the forward movement of said pawl when the magazine has been removed.

To prevent rearward movement of the cartridge magazine drum 10<sup>b</sup>, a stop pawl 20 is pivoted on a pin 20<sup>a</sup> to swing preferably in the same horizontal slot as the pawl 19, see Figs. 5 and 8. The pawl 20 co-operates with the same series of shoulders on the drum 10<sup>b</sup> as the feeding pawl 18, but engages them in a different plane. It is actuated to its operative position by a spring 20<sup>b</sup>. Its movement is limited in forward direction by a shoulder 20<sup>c</sup> thereon co-operating with a corresponding shoulder 2<sup>b</sup> on the top cover 2<sup>a</sup>, see Fig. 1.

By reference to Figs. 1, 2, 5, 6, 7 and 8, it will be seen that the noses of the pawls 18, 19 and 20 are each formed, at the top, with a forward and downward incline. This construction facilitates the placing of a magazine on the gun, the pawls being, in the downward movement of the magazine, cammed back by the engagement of the bottom of the cylindrical portion of the magazine drum with said inclines on the pawls.

The mounting of the feed lever carrying the feed pawl and the stop pawls in the manner shown and described on the movable top cover 2<sup>a</sup> of the breech casing, which cover is preferably hinged, as shown, at its rear end on the transverse pin 2<sup>c</sup>, provides a convenient and compact arrangement of these parts which permits easy access thereto and to the mechanism within the gun casing.

The top cover 2<sup>a</sup> is arranged to swing downwardly between the side plates, when in the closed position, so that its top, except at its vertically thickened forward portion, is flush with the tops of the side plates 1, 1 of the breech casing. The top of the thickened forward portion of the top cover 2<sup>a</sup> is laterally extended on both sides, these lateral extensions resting on top of the side plates, when the cover is in closed position. The cover is locked in said position by any

suitable means, such as a transversely sliding latch 21 mounted in a corresponding slide-way in the top cover near its forward end, the latch being actuated to its operative position, in which a nose thereon projects into a recess in the lefthand side plate 1 of the breech casing, by a spring 21<sup>a</sup>, see Fig. 1.

The means for transferring the cartridges from the position centrally over the barrel into the chamber of the barrel has been modified in several important respects from the prior construction to adapt them to the rotary drum feed. Because of the necessarily small vertical height between the head of a cartridge so positioned and the periphery of the drum, it was not found feasible, as in the prior patent, to combine the function of an extractor and a carrier in one element, because, to obtain the required strength for the rearward withdrawal of the cartridges from the position shown in Figs. 1 and 2, it would require making such element vertically too high to pass under the periphery of the magazine.

To this end a separate extractor 22 is provided, which is pivoted at 22<sup>a</sup> in a longitudinal recess on the left hand side of the breech block, see Figs. 9, 10 and 11, and has its forward hooked end 22<sup>b</sup> arranged substantially vertically above the left hand one of a pair of overhanging flanges forming a vertical guide way 23 in the face of the breech block, which flanges grasp the head of a cartridge in a usual manner as the same is moved downwardly from the grasp of the extractor hook 22<sup>b</sup> toward the barrel axis. The extractor 22 is actuated to its operative position by a spring 22<sup>c</sup>, see Fig. 11.

In the last of the forward movement of the breech block the extractor hook 22<sup>b</sup> passes over the head of the cartridge centrally positioned above the barrel, and engages into the usual groove therein forward of its head, whereby, on the succeeding rearward movement of the breech block the cartridge is rearwardly removed from said position.

To move the cartridge transversely to bring it into alignment with the barrel axis, a carrier 24 pivoted preferably by an integral pivot 24<sup>a</sup> to the left hand side of the breech block in a plane slightly below the extractor 22 and having its forward free end extend forwardly beyond the face of the breech block, is provided. The carrier has a lateral inward projection 24<sup>b</sup> at its forward end which is adapted to overlie a cartridge being transferred into the barrel chamber, see Figs. 2 and 5, and also carries at its forward end a pivoted ejector 25 similar in function and mode of operation to the ejector disclosed in my prior patent. The ejector is, in this case, mounted so as to engage the cartridge being transferred to the barrel on the left hand side instead of as in the

prior construction, on the right hand side. To control the transverse movements of the carrier a system of cams is provided, but instead of having one of the cams mounted on the top cover and acting on the rounded top of a combined extractor and carrier, as in the prior construction, the entire system of cams is, in the present construction mounted on the left hand side plate of the casing, an arrangement which makes for greater simplicity of construction.

This system of cams comprises an elongated upper cam plate 26, a switch lever 27 and a lower cam plate 28, see Figs. 2 and 5. Cam surfaces on these elements cooperate with an elongated integral lateral outward projection 24<sup>c</sup> on the forward portion of the carrier 24. The under side of the elongated upper cam plate 26 inclines rearwardly and downwardly, the inclination being very slight at its forward portion but increasing gradually toward the rear. In the recoil of the breech block, the lateral projection 24<sup>c</sup> on the carrier engages this inclined surface thereby gradually lowering the cartridge engaged by the extractor toward the barrel axis and causing its head to pass from the hook 22<sup>b</sup> of the extractor into the vertical flangeway 23 on the face of the breech block. In the continued rearward movement of the breech block, the lateral projection 24<sup>c</sup> engages the rear end of the switch lever 27, pivoted between its ends at 27<sup>a</sup> and depresses the same against the action of its spring 27<sup>b</sup> until, in the last of the rearward movement of the breech block, the projection 24<sup>c</sup> passes rearwardly beyond the switch lever, when the same will be snapped back by its spring 27<sup>b</sup> into the position shown in Fig. 2, where it closes the passageway between it and the upper elongated cam plate 26. On the forward movement of the breech block, the lateral projection 24<sup>c</sup> on the carrier engages the forwardly and downwardly inclined rear surface of the switch lever 27 whereby the cartridge is brought into alignment with the axis of the barrel, and in the further forward movement of the breech block is inserted in the barrel chamber.

In this last transverse movement of the carrier, if an empty shell remains in the grasp of the flangeway on the face of the breech block, it is downwardly ejected by the engagement therewith of the lower end of the ejector 25 in a usual manner.

In the forward movement of the breech block while the cartridge is being partly inserted in the barrel the lateral projection 24<sup>c</sup> on the carrier is guided between the bottom of the switch lever 27 and the top of the left hand portion of the barrel extension 7, but, in the further forward movement of the breech block to fully insert the cartridges into the barrel, the lateral projection 24<sup>c</sup> engages the forwardly and upwardly in-

clined rear surface of the cam plate 28, which lifts the carrier, in the continued forward movement of the breech block, to its highest position to allow its lateral inward projection 24<sup>b</sup> to pass over the head of the succeeding cartridge in position to be engaged by the extractor 22, see Figs. 2 and 5. In so moving to its highest position, the lateral projection 24<sup>c</sup> engages the under side of the forward arm of the switch lever 27, and raises the same against the action of its spring 27<sup>b</sup> which as soon as the projection 24<sup>c</sup> passes forwardly beyond the lever, returns the same to its normal position closing the passageway between the forward end of the lever and the cam plate 28.

By this construction, the transverse movements of the carrier are controlled entirely, both in the rearward and forward movements of the breech block, by the engagement of its lateral projection 24<sup>c</sup> with a system of cams arranged on the side plate of the casing.

While I have hereinbefore described the novel improved feeding mechanism in connection with an automatic machine gun of the Browning type, it will be understood that certain features thereof are equally applicable to other types of firearms, and I do not desire to be limited to the application of my invention to any particular type of automatic firearm except to the extent indicated by the claims appended hereto.

I claim:

1. In an automatic firearm having a recoiling member carrying an extractor for successively removing the cartridges in rearward direction from a position laterally of the barrel in the recoil of said member, the combination of a cartridge magazine having a rotary element provided with spacing means for the cartridges, means for rotating said element step by step, and means co-operating with the spacing means on the element for transferring the foremost cartridge in the magazine into position for engagement by the extractor on said recoiling member and for holding the cartridge in such position until it is removed in rearward direction.

2. In an automatic firearm having a recoiling member carrying an extractor for successively removing cartridges in rearward direction from a position laterally of the barrel in the recoil of said member, the combination of a frame, a cartridge magazine mounted thereon and having a discharge opening and a rotary element for causing the discharge of the cartridges successively through said opening, and means co-operating with said rotary element for guiding the foremost cartridge in the magazine through said opening and into position for engagement by the extractor on the recoiling member and for holding said cartridge in said



position until it is removed in rearward direction by said extractor, said means comprising stop projections on the frame to engage the cartridge, respectively, at its forward and rear portions, the rear projection having an inclined surface, whereby the head of the cartridge is brought into position for engagement by the extractor while the rotary element is rotated a step.

3. In an automatic fire arm having a recoiling member carrying an extractor for successively removing cartridges in rearward direction from a position laterally of the barrel in the recoil of said member, the combination of a cartridge magazine having a rotary drum provided with spacing elements for the cartridges, means for rotating said drum step by step, and means co-operating with said spacing elements whereby, in the stepwise rotation of said drum, a cartridge is transferred from the magazine into position for engagement by said extractor on the recoiling member and is held in such position until it is rearwardly removed, said holding means comprising abutments engaging one side of said cartridge, respectively, at the front and at the rear thereof and a spacing element of the magazine engaging the opposite side of said cartridge.

4. In an automatic firearm, the combination of a frame, a barrel, a cartridge magazine mounted on said frame and having a rotary drum, means for rotating said drum, means for moving the foremost cartridge in the magazine into a position in substantial parallelism with the axis of the barrel and holding it in said position until it is removed in the general direction of its axis, and means for so removing it and placing it into the chamber of the barrel, said moving and holding means comprising a fixed element having a cam surface and a cartridge spacing element on the rotary drum.

5. In an automatic firearm having a recoiling member carrying an extractor for successively removing cartridges in rearward direction from a position laterally of the barrel in the recoil of said member, the combination of a cartridge magazine having a rotary drum provided with spacing means for the cartridges, means for rotating said drum, and means co-operating directly with said spacing means for transferring the foremost cartridge in the magazine into position for engagement by said extractor on the recoiling member and for holding said cartridge in said position until it is rearwardly removed comprising a fixed cam-faced element.

6. In an automatic firearm, the combination of a breech block carrying an extractor and a carrier and having a vertical flangeway on its forward face adapted to

receive and grasp the head of a cartridge, the hook of said extractor being in vertical alignment with one side of said flangeway and the carrier being adapted to overlie a cartridge engaged by said extractor when the breech block is in forward position, and means whereby, in the movements of said breech block, the carrier is actuated to lower the cartridge from the grasp of the extractor into the vertical flangeway.

7. In an automatic firearm in which the cartridges are successively removed in rearward direction from a position above the barrel, the combination of a frame, a cartridge magazine supported thereon and having a rotary drum, means for rotating said drum step by step to bring the cartridges therein successively into said position, a breech block having a vertical flangeway on its face adapted to receive and grasp the head of a cartridge, an extractor carried by said breech block and having a hooked portion to engage the head of a cartridge located in said position when the breech block is forward, a carrier mounted for transverse movement on said breech block and having a portion adapted to pass between the bottom of the drum and the top of said cartridge so as to overlie the same when it is engaged by the extractor, the hook of said extractor and one side of said flangeway being substantially vertically aligned, whereby, in the lowering of the carrier to bring the cartridge in line with the barrel axis, the cartridge is transferred from said extractor into said flangeway.

8. In an automatic firearm in which the cartridge is transferred from a position substantially parallel to the barrel and laterally thereof into the barrel chamber during the recoil and return of a longitudinally reciprocating breech block, the combination of a flangeway in the face of said breech block adapted to grasp the head of a cartridge, an extractor on said breech block having a hooked portion for engaging a cartridge when the breech block is in forward barrel-closing position, the hooked portion of said extractor being in substantial alignment with one side of said flangeway, thereby forming with said flangeway a substantially continuous guideway, a carrier having transverse movement on said breech block, and means for actuating said carrier in the movements of said breech block to move the cartridge engaged by said extractor into said flangeway.

9. In an automatic machine gun having a recoiling breech block carrying an extractor for successively removing cartridges in rearward direction from a position laterally of the barrel in the recoil of said block, the combination of a cartridge magazine having a rotary drum, a feed lever carrying a pawl for actuating said drum step by step to

bring the cartridges therein successively into said position, and means for operating said lever comprising a stud thereon projecting into a cam groove in the top of said recoiling breech block.

10. In an automatic machine gun having a recoiling breech block provided with means for successively removing cartridges in rearward direction from a position laterally of the barrel in the recoil of said block, the combination of cartridge magazine having a rotary drum, a two-armed feed lever having a feed pawl at one end for engagement with the drum to rotate it step by step to bring the cartridges in the magazine successively into said position, and a stud at its other end projecting into a cam groove in the top of the breech block, the lever, pawl and cam groove being arranged to cause the stepwise movement of the magazine drum in the forward movement of said breech block.

11. In an automatic machine gun having a recoiling breech block carrying an extractor for successively removing cartridges in rearward direction from a position laterally of the barrel in the recoil of said breech block, the combination of a pivoted carrier mounted on said breech block and adapted to engage the cartridge being so rearwardly removed, said carrier having an integral projection thereon, and cams arranged on a side plate of the breech casing in co-operative relation with said projection to control the transverse movements of the carrier for bringing the cartridge engaged thereby into alignment with the barrel axis.

12. In an automatic machine gun having means for feeding a cartridge into a position laterally of the barrel and substantially parallel thereto, the combination of a reciprocating breech block carrying an extractor for removing a cartridge so positioned in rearward direction in the recoil of said block, a pivoted carrier on said breech block for bringing said cartridge, in the recoil and return movements of said breech block, into a position for insertion into the barrel chamber on the forward movement of said breech block, and means for imparting transverse movement to said carrier comprising

fixed cams and a switch co-operating solely with a lateral projection on the carrier to effect such transverse movement.

13. In an automatic firearm having a recoiling breech block and means for removing a cartridge in rearward direction from a position laterally of the barrel in the recoil of said breech block, the combination of a cam groove in the top of said breech block, a magazine having a rotary drum for successively bringing the cartridges therein into said position, and an operative connection between said drum and said cam groove for rotating the drum a step to bring the foremost cartridge therein into said position on each forward movement of said breech block.

14. In an automatic firearm, the combination of a casing carrying a post, a magazine seated on said post and having a fixed member and a rotary member, a latch on said casing for releasably securing the magazine on the gun, and means on the magazine and separate from the latch for disengaging the said latch to permit the removal of the magazine.

15. In an automatic firearm, the combination of a casing carrying a post, a magazine seated on said post and having a fixed member and a rotary member, a latch on said casing for releasably securing the magazine on the gun, and means on the magazine and separate from the latch for disengaging the said latch to permit the removal of the magazine, the said means comprising a slide carried by the fixed member of the magazine and movable transversely of the post.

16. In an automatic firearm, the combination of a casing carrying a post, a magazine seated on said post and having a fixed member and a rotary member, a latch on said casing for releasably securing the magazine on the gun, and means on the magazine and separate from the latch for disengaging the said latch to permit the removal of the magazine, the said means also serving to frictionally oppose relative movements of the two members of the magazine.

This specification signed and witnessed this 7th day of July, 1925.

JOHN M. BROWNING.