

1,293,022.

J. M. BROWNING,
AUTOMATIC MACHINE RIFLE.
APPLICATION FILED AUG. 1, 1917.

Patented Feb. 4, 1919.

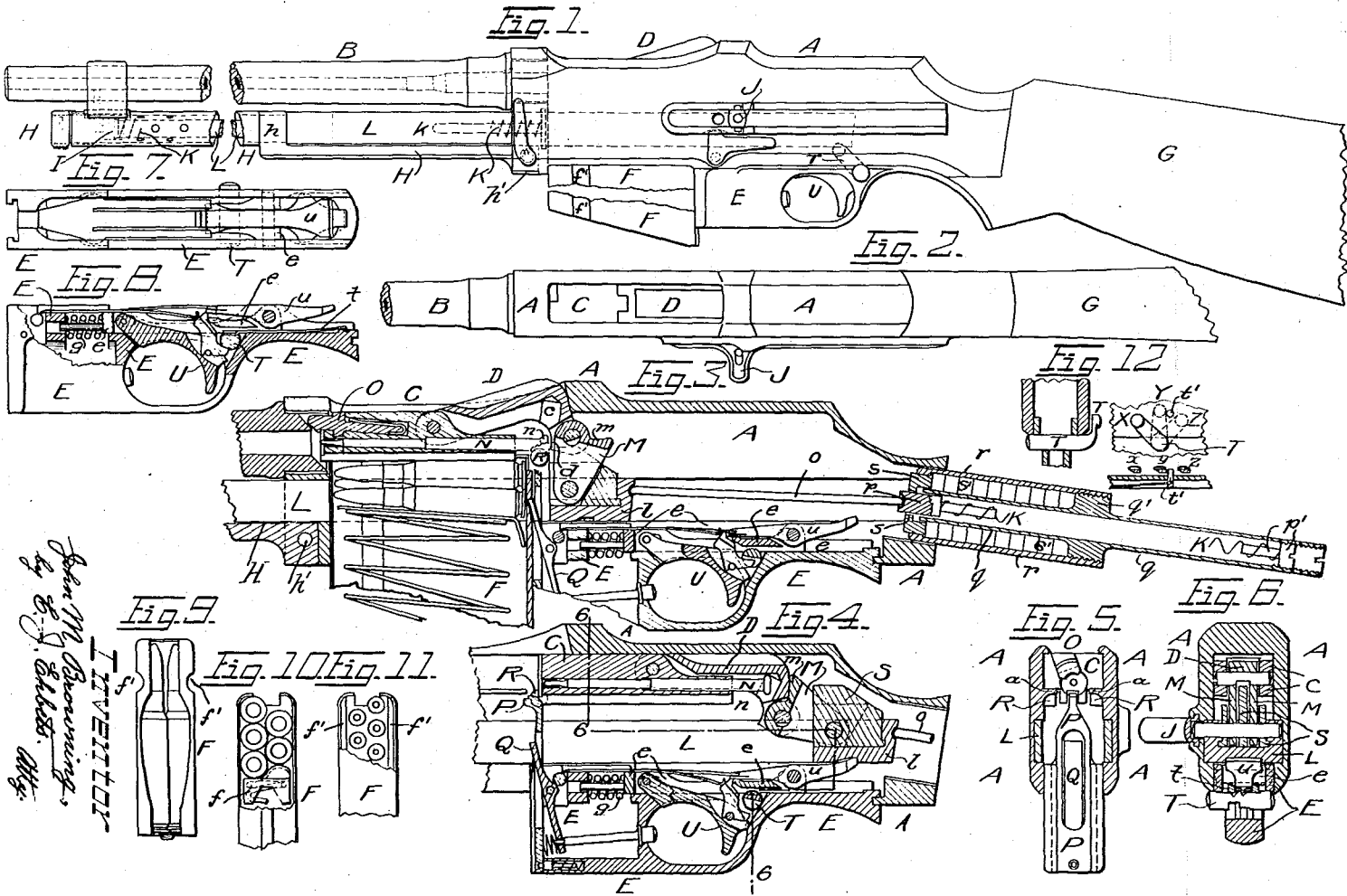

*John M. Browning,
by E. J. Galt, Atty.
INVENTOR*

D STA S PAT O CE.

JOHN M. BROWNING, OF OGDEN, UTAH.

AUTOMATIC MACHINE-RIFLE.

1,293,022.

Specification of Letters Patent.

Patented Feb. 4, 1919.

Application filed August 1, 1917. Serial No. 183,841.

To all whom it may concern:

Be it known that I, JOHN M. BROWNING, a citizen of the United States, residing in Ogden, in the county of Weber and State of Utah, have invented certain new and useful Improvements in Automatic Machine-Rifles, of which the following is a specification, reference being had to the accompanying drawings, forming a part hereof.

The invention generally relates to machine rifles in which all operations of the mechanism, except that of the trigger, are automatically effected, and in which the form and the weight of the rifle adapt it for using highly charged military ammunition, the shooter either lying prone upon the ground, or standing erect with only his hands and shoulder supporting the rifle.

The invention specially relates to novel improvements in gas-operated machine rifles in which a vent in the barrel leads to a gas cylinder kept below the vent by a band allowing the barrel to expand lengthwise. The forward end of the cylinder is closed, the rear end fixed in the breech casing. The gas cylinder has a series of radial openings through which the powder gases escape after having exerted pressure upon the gas piston in the cylinder. Some distance forward of the breech casing the gas cylinder carries a block from the bottom of which a bar extends to the breech casing where it is fixed.

The main object of the invention is to provide a machine rifle adapted to fire highly charged military cartridges, but so light in weight as to allow of one person carrying it and firing it from the shoulder, and yet most durable. This object is attained by providing novel constructions for transforming the necessarily very rapid movements of members of the mechanism at certain points of their path, yet thereby not reducing the rate of speed of the operation of the arm, but rather at will increasing same. Heretofore, most firearms of this class firing highly charged cartridges and having a high rate of speed of operation, though heavier and apparently stronger, have been injured or wracked to pieces by a comparatively short use.

In the accompanying drawings:

Figure 1 represents a left hand side elevation of the machine rifle, with portions broken away.

Fig. 2 represents a top view of the central portion of the machine rifle.

Fig. 3 represents the same portion in a longitudinal vertical section showing the breech mechanism with the breech block in the forward locked position.

Fig. 4 represents a similar view to Fig. 3, but with the breech block unlocked and moved to its rearmost position.

Fig. 5 represents a front view of a vertical transverse section through the receiver at a place somewhat forward of the front end of Fig. 4, and with the parts in the same position as in Fig. 4, looking rearward; the magazine being removed, and the magazine guide, shell ejector, the magazine latch and the breech block shown in front view.

Fig. 6 represents a vertical transverse section in the line 6-6 of Fig. 4, through the receiver and trigger plate, and the parts therein, seen from the rear, the sear, the sear shifting button or firing controller and the handle and its arbor being represented as not in section.

Fig. 7 represents a top view of the trigger plate detached, with the parts contained therein.

Fig. 8 represents a vertical longitudinal section of the trigger plate with the parts therein.

Fig. 9 represents a top view of the cartridge magazine detached.

Fig. 10 represents an upper portion of the cartridge magazine partly in section, so as to expose to view the magazine follower, a part of the follower spring, and a number of cartridges resting upon said follower, seen from the rear.

Fig. 11 represents a portion of the cartridge magazine, an upper part of which is in section, so as to expose to view some of the cartridges therein, seen from the front.

Fig. 12 represents in the three positions, X, Y, Z, the new rotary shifter T and the positive spring-supported stop t^1 for same.

Similar letters refer to similar parts throughout the several views.

The machine rifle represented in the drawings comprises the following main parts: the breech casing A, the barrel B secured to the breech casing, the breech block C and the locking brace D; the trigger plate E closing at the bottom the rear portion of the breech casing, the cartridge magazine F inserted from below into the breech casing and locked there in front of the trigger plate, and the butt stock G.

The barrel B has a vent. Below the vent is the gas cylinder H, its front end closed, its rear end fastened in the breech casing. Some distance forward of the breech casing the cylinder H takes the form of a cubical block *h* from the under side of which a flat guide bar extends into the breech casing and is locked therein by a transverse pin *h*¹. In the cylinder the piston head I is fitted from which the piston rod L of slightly smaller diameter extends rearward through the cylinder H and the cubical block *h*. In rear of the block the piston rod L carries a crosshead from which a lug depends into a groove in the guide bar H, and from the crosshead rearward it forms the action slide, being divided in two side bars separated by an open space of sufficient width for the passage of the cartridge magazine therethrough; at the rear end of the action slide L the two side bars are united by an integral crossbar *l*. The breech casing below the barrel has a wide opening for the entrance of the rear end of the action slide and two internal grooves in which the side bars of the slide are guided. After the crossbar *l* has passed into the casing through said opening a plate is removably fitted in the casing below the barrel from which a short guide rod *k* extends some distance in front of the breech casing.

Slightly in rear of the vent the cylinder H has a series of holes through which the powder gases may escape after exerting their pressure upon the piston I. Either on the piston rod L and between it and the cylinder H the usual reaction spring K is located, its forward end bearing against the piston head I its rear end against the face of the block *h* of the cylinder; or the piston rod L may be tubular and contain the forward end of the reaction spring K the rear end of which is in that case supported by the guide rod *k* and plate fastened in the breech casing.

It is obvious that when the reaction spring is fully compressed by the rearward movement of the piston I under the pressure of the gases, the reaction spring K not only serves to return the piston and action slide forward, but it also serves to cushion the action slide by absorbing any excess of energy.

This arrangement of the gas vent, cylinder and piston, with the reaction spring on the piston rod or in the piston rod, located alongside the barrel for the automatic operation of the action slide, is a well known one and needs no further illustration or description.

In Fig. 3 an alternate of this arrangement is shown in which the tube containing the reaction spring and the piston actuated thereby are located in rear of the breech mechanism. The main difference in this arrangement from the former one is that a

reaction spring K and a separate buffer plate *s* with a resilient cushion *s*¹ are provided. The arrangement of the reaction spring and its piston in the butt stock, and of the intermediate means between the reaction spring and the action slide for moving the same forward is also well known, and therefore, needs not to be further described, with the exception of the inter-relation between the buffer and the reaction spring and piston clearly shown in Fig. 3, in which the cylindrical tube *q* containing the reaction spring K and the piston *p*, carries on its exterior a strong annular collar *q*¹ upon the outside of which is attached by a screw thread the rear end of a second larger tube *r*, which extends forward somewhat beyond the inner smaller tube *q*; the interiorly shouldered front end of the larger tube *r* is closed by a shouldered annular buffer plate *s* which projects forwardly beyond the end of the tube *r* and is rearwardly movable therein. Through the central opening in the buffer plate *s* the piston *p* of the reaction spring may freely slide, and the space between the collar on the smaller tube and the buffer plate *s* is packed with annular disks *s*¹ or coils of a resilient material. The rear end of the smaller tube *q* is closed by an adjustable screw plug *p*¹ which carries centrally upon its forward face a guide pin for the rear end of the reaction spring K. From the piston *p* a rod *o* extends forward to the reaction slide L. The face of the piston and the end of the slide are both provided with a recess in which the rounded ends of the rod *o* rest. The constant pressure of the reaction spring prevents the ends of the rod from leaving the recesses. See Fig. 3.

By this simple and compact construction the plate *s* not only acts as a buffer to cushion and absorb any excess of energy of recoil residing in the action slide L at the limit of its rearward movement, and to assist the reaction spring K in returning the action slide and the breech block forward; but by screwing the inner smaller tube *q*, and the collar *q*¹ thereon more or less into the larger tube *r*, the degree of resiliency of the buffer may be readily adjusted by the degree of compression of the packing *s*¹, and thereby the starting of the return movement of the action slide and the breech block may be made quicker or slower, so as to cause a more rapid or a slower rate of automatic firing of the rifle.

The rear of the barrel is closed by the breech block C fitted to reciprocate in the breech casing A guided there vertically by the top of the casing and two longitudinal ribs *a* which project inward from the sides of the casing. See Fig. 5. The breech block C for its support in the forward firing position carries a pivotally attached locking

brace D, the rear of which is adapted to be raised in front of a strong abutment formed on the top of the breech casing A. Below the breech block is the chamber for holding the cartridge magazine, as seen in Figs. 3 and 9 to 11. The magazine is a rectangular box F which contains two columns of cartridges side by side in staggered relation upon the spring-actuated follower *f*, and has in each side wall a vertical inwardly projecting guide rib *f'*. Between the narrow parallel top openings at both ends of the magazine, the over-hanging edges of the sides form a wide curved opening. The front and rear walls have each a recess which permits the lower portion of the breech block to slide lengthwise through the magazine. The rear portion of the cartridge chamber in the barrel is inwardly chamfered to form at the bottom and both sides an upward and inward conical incline leading into the cartridge chamber.

When the breech block moves forward from its rearmost position, its lower portion engages the topmost cartridge in the magazine and forces it forward. As the bullet encounters the chamfer, in its continued forward movement, its point is forced inward and upward, the narrow forward opening in the top of the magazine permitting the small bullet to pass out of the magazine. By this simultaneous forward, upward and inward movement the cartridge is caused to incline in its entire length, and, as during this movement the large portion of the cartridge has reached the wide central opening in the top of the magazine, it can leave the same and the breech block can fully force the cartridge into the chamber of the barrel. This insertion directly from the wide square box magazine into the barrel is effected as readily with the cartridges in the right hand column as with those in the left hand one, as the chamfer in the barrel will guide the rising cartridges from either side into the chamber.

The breech block is provided with the firing pin N, shell extractor O, and has in its bottom a central groove for the shell ejector P. The firing pin N at its rear end has an enlarged head *n* and the locking brace has in its under side a central longitudinal groove for clearing the body of the firing pin. Near its rear end the locking brace has an upwardly extending hole *c* connected with the groove, for the head *n* of the firing pin, the forward edges of this hole *c* acting like a cam upon the head *n*, so that as the locking brace is lowered the firing pin is positively retracted to its rearmost position in which its firing point is withdrawn into the breech block, thus making a positive safety device.

The locking brace below its rear end extends downward and has a boss *d* divided

by a central recess in which the link M is attached by its upper pivot, the lower pivot of the link being attached to the crossbar *l* of the action slide.

At the place where the bottom of the locking brace and the front face of its downward extension meet, a double cam of substantially quadrantal form is provided; said cam consists of an upper portion curving downward from the horizontal under side of the brace and of a lower portion curving forward from the vertical face of the extension, both of these curved portions being connected.

By the first rearward movement of the action slide the locking brace is lowered to unlock the breech block and is stopped by the stop studs R, R, provided in the breech casing. As the brace is lowered, instead of it striking a violent blow upon the top of the stops R, R, the lower portion of the cam will engage the rear of the stops with a glancing blow. At the instant when the top of the lowered brace clears the inside of the breech casing, the cam transforms the downward movement of the brace into a longitudinal rearward one and thus prevents injury to brace or stops. In addition to the cam on the brace for preventing a violent blow upon the stops as just described, the link M is provided in rear of its upper pivot with a shoulder *m*, shown in Fig. 3 as extending nearly horizontally rearward from the link when the brace is in the upper breech block-locking position. When the brace is lowered by the downward pull on it of the link as the same is drawn rearward by the action slide, the projecting shoulder *m* is turned upward and forward upon the upper link pin as a fulcrum, until, after the rounded rear corner of the top of the brace has fully cleared the under surface of the breech casing, the shoulder *m*, then nearly vertical is brought up against the rear face of the brace, and as the link then draws the brace rearward, it thereby increases the action of the cam in transmitting rearward movement to brace and breech block. Consequently, when the rapidly rearward moving action slide commences through the link to draw along the breech block and brace, it finds these members already started in the rearward direction; therefore, any sudden strain upon the action slide, link, its pivots, brace and breech block due to their inertia is avoided and these parts are thereby saved from injury to which they would be exposed were the movement of the action slide suddenly transferred to them while they stood still.

In consequence of the exceedingly rapid rate of firing required of automatic firearms, the reciprocating members of the breech mechanism as well as the action slide must be easily started, then moved at a greatly

increased speed, and, finally, the resulting blows at the ends of the movements of all parts must be cushioned to prevent injury to the members.

5 During the recoil, as well as during the forward movement, the members of the breech mechanism must move freely and without frictional contact with their longitudinal guides. To insure this freedom of
10 their movements, the following arrangement, clearly represented in the drawings, is provided.

During the first of the rearward movement of the action slide under the blow-like
15 effect of the powder gases against the gas piston, the action slide draws down the link and brace and thus unlocks the breech block and starts the breech block rearward when the rounded upper rear corner of the locking
20 brace can slide under the abutment on the receiver. The speed of the rearward movement of the action slide is then gradually diminished by the compression of the reaction spring, which aided by the buffer
25 spring, finally stops the slide entirely and returns it forward.

During this rearward movement the centers of the three pivot pins lie substantially
30 in a straight line inclining rearward and downward, but with the central pivot slightly below this line to which position the rounded rear corner of the locking brace, when sliding under the abutment, has forced the center of the middle pivot, as
35 hereinbefore described.

The momentum of the heavy breech block after rapid rearward movement has been imparted to it by the action slide, is not directly absorbed or diminished, so that
40 during the rearward movement the breech block actually pushes the brace, link and slide rearward, and thereby prevents the middle pivot from rising and thus keeps the top of the breech block and locking brace
45 from frictional contact with the inner surface of the top of the receiver, a freedom which would not result if the rearward movement were still due to the drawing by the slide of the link and brace, as such drawing
50 instead of depressing would tend to raise the middle pivot and thereby also the top of the brace.

During the ensuing forward movement, and up to the point where the cam of the
55 brace strikes the studs R, R, the action slide, link, locking brace and breech block remain relatively in the same position in which they are shown in Fig. 4, with the center of the pivot pin connecting the locking brace with
60 the breech block and the center of the pivot pin connecting the link with the action slide in a straight line inclining rearward and downward, but with the center of the middle
65 pivot pin connecting the link with the brace below this line; by this disposition and be-

cause again a push transmits the movement of the action slide to the link, brace and breech block, it keeps down the middle pivot pin and the brace and again presents frictional contact of the same with the under
70 side of the top of the breech casing, and thus greatly facilitates the forward closing movement of the breech block.

Rigidly attached to the crossbar *l* is the hammer or striker *S*. Its central portion
75 projects upward into the path of the firing pin head *n* and on the last of the forward movement of the action slide, after the link has raised the brace *D* and thereby locked the breech block *C* in the firing position, the
80 projection of the hammer strikes upon the head *n* of the firing pin, and this percussion ignites the primer of the cartridge. During this forward movement of the action slide and the transforming of this movement into
85 the vertical one necessary to raise the locking brace, the reversed action of the link and that of the upper portion of the cam of the brace on the stops *R, R*, cushions the forward movement of the breech block so that
90 the same will confine the cartridge in the chamber of the barrel without delivering a blow liable to injure the operating parts.

In the present embodiment of the important improvements the rearwardly moving
95 action slide is stopped either by the combined reaction and cushion spring located below the barrel, or by the combined action of the reaction spring *K* and of the separate cushioned buffer plate *s* in the butt
100 stock by which the action slide is returned forward in its counter-recoil. If the rifle is to be fired with reduced or with increased speed by at will firing single shots each controlled by the trigger *U*, a device is provided
105 for absorbing any excess of counter-recoil, shown in Figs. 3, 4, 7 and 8. Unless depressed by the operation of the trigger, which is mounted on a fixed pivot pin in the trigger plate *E*, the rear end of the two
110 armed sear *u* serves as a stop for the action slide *L*, by engaging a notch in the bottom of the integral cross bar *l* of the slide; the sear *u* is pivoted above the trigger *U* and its pawl in the separate slide *e* lengthwise
115 movably mounted in a recess in the top of the trigger plate *E*, and the slide *e* carries on a pin on its front a strong helical buffer spring *g*, the forward end of which rests against a fixed point of the trigger plate *E*,
120 while a horizontal slot in the slide *e* for the trigger pivot pin is provided to allow this movement. The buffer spring *g* thus absorbs the blow of the counter-recoil and prevents injury to the rear end of the sear.
125

The present embodiment of the automatic rifle as represented in Figs. 3, 4, 6, 7 and 8, is provided with a laterally sliding shifter *T* mounted in a transverse seat in the trigger
130 plate above the upper rear end of the trig-

ger U, which serves for at will changing the firing mechanism from the position in which single shots may be fired under the control of the trigger, to the position in which volleys of shots may be fired and controlled by the operation and retention of the trigger and its release and by the capacity of the magazine, or to the safety position where firing is entirely prevented by locking the trigger and sear against operation. From the under side of the shifter T above the trigger, several segments have been removed so as to form a series of steps of varying depth, which may at will be brought above the rear end of the trigger by the laterally sliding movement of the shifter.

In Fig. 6 the shifter T and the several steps in its under side are clearly shown, and above it a spring *t*, also shown in Fig. 8, and several notches to frictionally keep the shifter in any of its several positions.

In Fig. 4 the shifter T is shown in the position in which single shots may be fired. The rear end of the sear *u* standing in the notch of the action slide holds the latter in its rear position from which it will be released if the trigger is pulled.

In Fig. 3 the parts are also shown in the position for firing single shots, but the trigger has been pulled so as to cause the sear to release the action slide which has been returned forward. The pawl pivoted in the trigger has raised the forward end of the sear for releasing the slide L, and the pawl has then been thrown with its upper end forward, beyond the front end of the sear, by striking the front face of a cross bar in the slide *e*, which face is inclined forward and upward; by this arrangement the sear is released to again engage the notch in the action slide when the same is next thrown to the rear by the firing of a shot.

In Fig. 8 the parts are shown adjusted for automatic firing, and the trigger is represented as having been pulled and retained in its rear position, whereby the rear end of the sear *u* has been lowered entirely out of the path of the action slide by the trigger pawl raising the front end of the sear *u*, the pawl being kept in operative position by its rear end bearing against the shifter T. On firing, the action slide will be thrown to the rear, and, not being retained by the sear, will be at once returned forward as long as cartridges for continued automatic firing are supplied.

In Fig. 12 is represented an improved or rotatory shifter T for changing the controlling mechanism from the single shot position to the volley position, or to the locked position. As shown in the partial section the rotatory shifter consists in a strong pivot mounted and located in the trigger plate and provided with a series of peripheral recesses of varying depth, from

which pivot a crank arm extends upward, which arm may be moved from the forward position X to the central position Y or to the rearward position Z, these three positions being also clearly represented in a small, horizontal section shown in Fig. 12. There is no obstacle to change the shifter from the forward position X to the central position Y, but when arrived at the central position Y a small horizontal stop pin *t'* projects from the side of the casing and positively prevents the shifter arm from being rotated to the rearward position Z until the stop *t'* is pushed inward, which cannot be done except by intentional pressure upon the end of the stop *t'*. After the stop *t'* has been pushed out of the path of the shifter arm T and the same has been turned to the rear position the shifter may at any time be again moved from its rearmost locking position to the volley firing central position and from there to the single shot firing forward position by simple pressure against the upper part of the shifter arm in the forward direction, because the forward edge of the shifter arm is slanting inward and rearward so as to automatically press the stop pin *t'* out of its path when the shifter arm is moved in the forward direction; but the rear edge of the shifter arm being square or vertical to the side of the casing, when it encounters the stop pin in its rearward movement the stop will positively hold it until the stop itself is removed out of the shifter's path which cannot be done accidentally, but only by the deliberate and intentional action of the operator. By this means the shifter may be readily moved for bringing into action the volley firing instead of the single firing, but cannot be accidentally moved too far and, therefore, stop all firing at a time when it is desired to shoot a number of shots with the greatest possible rapidity by holding the trigger. It would be a fatal fault if the shifter arm were unintentionally moved too far to the rear just at the time when the operator wanted the most rapid fire and maximum number of shots. This accident is positively prevented by the provision of the stop *t'* described.

I claim:

1. In an automatic firearm, the combination of a breech casing, a barrel supported thereby, a reciprocating breech block mounted in said breech casing for reciprocation in a right line for opening and closing said barrel, a locking brace pivoted to said breech block, an abutment on the breech casing for engaging the rear face of said locking brace, a reciprocating gas-operated action slide located below said locking brace, a gas-cylinder and piston for operating said action slide, a link pivoted to the rear end of said locking brace and to said action

slide, and a shoulder on said link for engagement with the rear face of said locking brace during the reciprocation of said breech block.

2. In an automatic firearm, the combination of a breech casing, a barrel supported thereby, a reciprocating breech block mounted in said breech casing for reciprocation in a right line for opening and closing said barrel, a locking brace pivoted to said breech block and having a rear locking face, an abutment on the breech casing having a locking surface extending to the lower surface of the upper portion of the breech casing for engaging the rear locking face of said brace and preventing any rearward movement of said breech block until the locking face of said brace has been pulled downward below the lower edge of said abutment, a reciprocating gas-operated action slide located below said locking brace, a gas cylinder and piston for operating said action slide, a link connection between said brace and said action slide, whereby when said action slide moves rearward the rear end of said brace is first pulled downward and thereafter said brace and the breech block are drawn rearward, a cam surface upon the underside of said locking brace, and stationary means so located upon said breech casing as to be engaged by said cam surface after the rear end of said locking brace has been pulled downward sufficiently to bring its locking face below the lower edge of said abutment, whereby the downward movement of said locking brace is stopped without violent blows and said breech block is started rearward without sudden strains upon the parts connecting it with the action slide.

3. In an automatic firearm, the combination of a breech casing, a barrel supported thereby, a reciprocating breech block mounted in said breech casing for reciprocating in a right line for opening and closing said barrel, a locking brace pivoted to said breech block, an abutment on the breech casing for engaging the rear face of said locking brace, a reciprocating action slide located below said locking brace, a gas cylinder and piston for operating said action slide in one direction, a reaction spring for operating said action slide in the other direction, a link between said brace and said action slide whereby when said action slide moves rearward, the rear end of said brace is first pulled downward and said brace and the breech block are thereafter drawn rearward, and when said action slide moves forward said brace and said breech block are forced forward and the rear end of said brace is thereafter forced upward, a cam surface upon the underside of said locking brace, and stationary means upon said breech casing engaged by said cam surface when the

rear end of said locking brace is pulled downward or forced forward and upward, whereby the downward movement and the forward movement of said locking brace are stopped without violent blows.

4. In an automatic firearm, the combination of a breech casing, a barrel supported thereby, a reciprocating breech block mounted in said breech casing for reciprocating in a right line for opening and closing said barrel, a locking brace pivoted to said breech block, an abutment on the breech casing for engaging the rear face of said locking brace, a reciprocating action slide located below said locking brace, a gas cylinder and piston for operating said action slide in one direction, a reaction spring for operating said action slide in the other direction, a link connection between the said brace and said action slide, a cam surface upon the under side of said locking brace substantially quadrantal in form, and correspondingly shaped stationary means upon said breech casing engaged by the lower portion of said cam surface when the rear end of said locking brace is pulled downward, and engaged by the upper portion of said cam surface when said locking brace is forced forward, whereby the downward and the forward movements of said locking brace are stopped without violent blows.

5. In an automatic firearm, the combination of a breech casing, a barrel supported thereby, a reciprocating breech block mounted in said breech casing for reciprocating in a right line for opening and closing said barrel, a locking brace pivoted to said breech block, an abutment on the breech casing for engaging the rear face of said locking brace, a reciprocating action slide located below said locking brace, a gas cylinder and piston for operating said action slide in one direction, a reaction spring for operating said action slide in the other direction, a link connection between the said brace and said action slide, a cam surface upon the under side of said locking brace comprising two connected curved portions, and correspondingly curved stationary means upon said breech casing engaged by one of said curved portions when the rear end of said locking brace is pulled downward and engaged by the other of said curved portions when said locking brace is forced forward, whereby the downward and the forward movements of said locking brace are stopped without violent blows.

6. In an automatic firearm, the combination of a breech casing, a barrel supported thereby, a reciprocating breech block mounted in said breech casing for reciprocation in a right line for opening and closing said barrel, a locking brace pivoted to said breech block, an abutment on the breech casing for engaging the rear face of said locking brace,

a reciprocating gas-operated action slide located below said locking brace, a gas cylinder and piston for operating said action slide, a link connection between said brace and said action slide, whereby when said action slide moves rearward the rear end of said locking brace is first pulled downward and thereafter said brace and breech block are drawn rearward, a cam surface upon the under side of said locking brace, stationary means upon said breech casing engaged by said cam surface when the rear end of said locking brace is pulled downward or pushed upward, and a shoulder on said link for engagement with the rear face of said locking brace during the reciprocation of said breech block.

7. In an automatic firearm, the combination of a breech casing, a barrel supported thereby, a reciprocating breech block mounted in said breech casing for reciprocation in a right line for opening and closing said barrel, a locking brace pivoted to said breech block, an abutment on the breech casing for engaging the rear face of said locking brace, a reciprocating gas-operated action slide located below said locking brace, a gas cylinder and piston for operating said action slide, a link pivoted to said brace and to said action slide, whereby when said action slide moves rearward the rear end of said locking brace is first pulled downward and thereafter said brace and the breech block are drawn rearward, a shoulder on said link for engagement with the rear face of said locking brace with the center of the pivot pin connecting said link to said brace lying below a line joining the centers of the pivot pin connecting said brace to said breech block and the pivot pin connecting said link to said action slide, during reciprocation, a cam surface upon the under side of said locking brace, and stationary means upon said breech casing engaged by said cam surface when said breech block is being moved forward to close said barrel, whereby the forward movement of said locking brace and breech block is stopped without violent blows, and said locking brace is forced upward, raising above said line the center of said pivot pin connecting said locking brace to said link.

8. In an automatic firearm, the combination of a breech casing, a barrel supported thereby, a reciprocating breech block mounted in said breech casing for reciprocation in a right line for opening and closing said barrel, a locking brace pivoted to said breech block, an abutment on the breech casing for engaging the rear face of said locking brace, a reciprocating gas-operated action slide located below said locking brace, a gas cylinder and piston for operating said action slide, a link pivoted to said brace and to said action slide, whereby when said action slide

moves rearward the rear end of said locking brace is first pulled downward and thereafter said brace and the breech block are drawn rearward, a cam surface on the upper side of said locking brace co-acting with said abutment to depress the locking brace, a shoulder on said link for engagement with the rear face of said locking brace with the center of the pivot pin connecting said link to said brace lying below a line joining the centers of the pivot pin connecting said brace to said breech block and the pivot pin connecting said link to said action slide during reciprocation, a cam surface upon the underside of said locking brace, and stationary means upon said breech casing co-acting with said last mentioned cam surface when said locking brace is pulled downward, and when said breech block is moved forward to close said barrel.

9. In an automatic firearm, the combination of a breech casing, a barrel supported thereby, a reciprocating breech block for opening and closing said barrel, a reciprocating gas-operated action slide, a gas cylinder and piston for operating said slide, a shoulder on said action slide, a trigger plate closing the bottom of said breech casing, a pivoted sear for engaging said shoulder on the action slide upon the forward movement of said action slide, a spring cushioned slide mounted in said trigger plate upon which said sear is pivoted, a trigger pivoted in said trigger plate for movement about its pivot only, a pawl pivoted on the trigger for tripping said sear and thereafter releasing same, or for holding said sear in inoperative position where said sear will not engage the shoulder on said action slide, and means for varying the limit of movement of the trigger and pawl whereby the firing may at will be changed from single shot to volley firing.

10. In an automatic firearm, the combination of a breech casing, a barrel supported thereby, a reciprocating breech block for opening and closing said barrel, a reciprocating gas-operated action slide, a gas cylinder and piston for operating said slide, a shoulder on said action slide, a trigger plate closing the bottom of said breech casing, a pivoted sear for engaging said shoulder on the action slide upon the forward movement of said action slide, a spring cushioned slide mounted in said trigger plate upon which said sear is pivoted, a trigger pivoted in said trigger plate for movement about its pivot only, a pawl pivoted on the trigger for tripping said sear and thereafter releasing same, or for holding said sear in inoperative position where said sear will not engage the shoulder on said action slide, a cam surface on said spring cushioned slide for engaging said pawl and disengaging it from said sear, and

means for varying the limit of movement of the trigger and pawl whereby the firing may at will be changed from single shot to volley firing.

- 5 11. In an automatic firearm, the combination with breech mechanism, firing mechanism and mechanism for controlling the firing, of a rotatory shifter for engaging the mechanism for controlling the firing, whereby the firing may at will be changed from
10 single shot to volley firing, or, whereby the mechanism for controlling the firing may be locked against operation, an arm on said shifter for rotating same, a removable stop
15 in the path of said arm positively preventing movement of said shifter from volley firing position to locked position, but yielding to permit movement of said shifter from locked position to volley firing position.
20
12. In an automatic firearm, the combination of a breech casing, a barrel supported thereby, a reciprocating breech block for opening and closing said barrel, a locking
25 brace pivoted to said breech block, an abutment on the breech casing for engaging the rear face of said locking brace, a reciprocating gas-operated action slide located below said locking brace, connections between
30 said action slide and said locking brace whereby said locking brace is pulled downward when said action slide moves rearward, a firing pin mounted for reciprocation in said breech block and having at its rear end
35 an enlarged head, and a hole or recess extending into the lower portion of said locking brace and adapted to fit over said head, said hole having its forward wall slotted, the two edges of said slot engaging said
40 head on each side of the firing pin and retracting the firing pin when the locking brace is pulled downward and thereafter positively holding said firing pin retracted until said breech block has returned to closed
45 position.
13. In an automatic firearm, the combination of a breech casing, a barrel supported thereby, a reciprocating breech block for opening and closing said barrel, a locking
50 brace pivoted to said breech block, an abutment on the breech casing for engaging the rear face of said locking brace, a reciprocating gas-operated action slide located below said locking brace, connections between
55 said action slide and said locking brace whereby said locking brace is pulled downward when said action slide moves rearward, a firing pin mounted for reciprocation in said breech block and having at its
60 rear end an enlarged head, a central longitudinal groove in the underside of said locking brace, terminating at its rear end in a wider recess or hole, whereby when said locking brace is pulled downward said
65 groove accommodates the body of said fir-

ing pin while the two edges of said recess engage said head of the firing pin on each side thereof, positively retracting the firing pin and holding it retracted throughout the reciprocation of the breech block. 70

14. In an automatic firearm, the combination of a breech casing, a barrel supported thereby, a reciprocating breech block for opening and closing said barrel, a locking
75 brace pivoted to said breech block, an abutment on the breech casing for engaging the rear face of said locking brace, a reciprocating gas-operated action slide located below said locking brace, connections between said
80 action slide and said locking brace whereby said locking brace is pulled downward when said action slide moves rearward, a firing pin mounted for reciprocation in said breech block and having a projection on its rear
85 end, a cam surface upon the underside of said locking brace for engaging said projection and retracting said firing pin when the locking brace is pulled downward and thereafter positively holding said firing pin
90 retracted until said breech block has returned to closed position, and a hammer rigidly mounted upon said action slide for striking said firing pin after the breech block has returned to closed position and
95 said locking brace has been raised to release the firing pin and to lock the breech block.

15. In an automatic firearm, the combination of a breech casing, a barrel, a reciprocating breech mechanism for opening and closing said barrel, an annular buffer plate
100 in rear of the breech mechanism against which said mechanism strikes at the end of its rearward movement, a tube in the forward end of which said buffer plate is mounted, means upon said tube engaging
105 said buffer plate for preventing forward movement of said plate while permitting free rearward movement thereof, a plug for closing the rear end of said tube, a tube of smaller diameter extending through and rigidly
110 supported by said plug and extending through the first mentioned tube and into said buffer plate, a reaction spring contained within said tube of smaller diameter, a piston cooperating therewith, and connections
115 from said piston to said breech mechanism.

16. In an automatic firearm, the combination of a breech casing, a barrel, a reciprocating breech mechanism for opening and closing said barrel, an annular buffer plate
120 in rear of the breech mechanism against which said mechanism strikes at the end of its rearward movement, a tube in the forward end of which said buffer plate is
125 mounted, means upon said tube engaging said buffer plate for preventing forward movement of said plate while permitting free rearward movement thereof, a plug for closing the rear end of said tube adjustable
130

toward and from said buffer plate, a packing of resilient material extending from said buffer plate to said plug, a tube of smaller diameter extending through and rigidly supported by said plug and extending through the first mentioned tube and into said buffer plate, a reaction spring contained within said tube of smaller diameter, a piston cooperating therewith, and connections from said piston to said breech mechanism.

17. In an automatic firearm, the combination of a breech casing, a barrel, a reciprocating breech mechanism for opening and closing said barrel, an annular buffer plate in rear of the breech mechanism against which said mechanism strikes at the end of its rearward movement, a tube in the forward end of which said buffer plate is mounted, means upon said tube engaging said buffer plate for preventing forward movement of said plate while permitting

free rearward movement thereof, a plug for closing the rear end of said tube adjustable toward and from said buffer plate, a packing of resilient material extending from said buffer plate to said plug, a tube of smaller diameter extending through and rigidly supported by said plug and extending through the first mentioned tube and into said buffer plate, a reaction spring contained within said tube of smaller diameter, a piston cooperating therewith, connections from said piston to said breech mechanism, and a plug for closing the rear end of said last mentioned tube adjustable toward and from said piston.

This specification signed and witnessed this 27th day of July, A. D. 1917.

JOHN M. BROWNING.

In the presence of—

C. J. EHBETS,

A. L. ULRICH.