

No. 728,739.

PATENTED MAY 19, 1903.

F. RITTER VON MANNLICHER.  
AUTOMATIC FIREARM.

APPLICATION FILED DEC. 22, 1902.

NO MODEL.

2 SHEETS—SHEET 1.

*Fig. 1.*

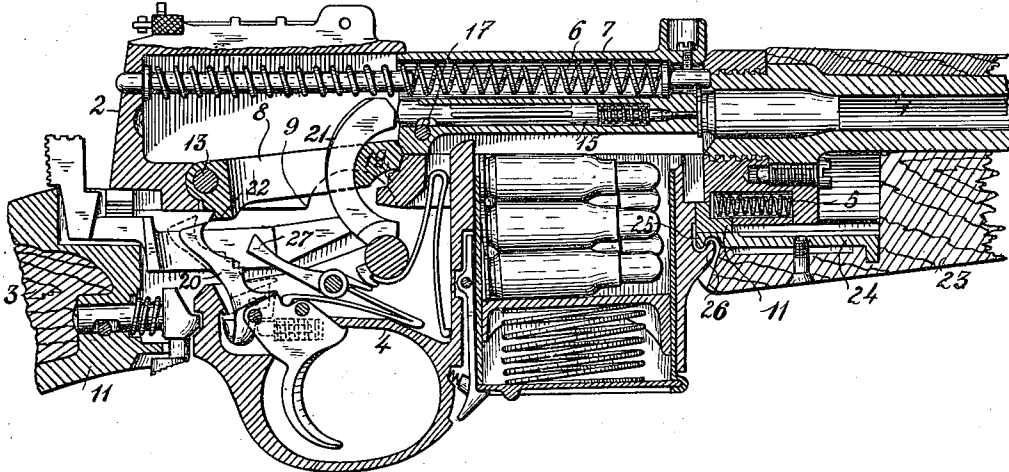

*Fig. 2.*

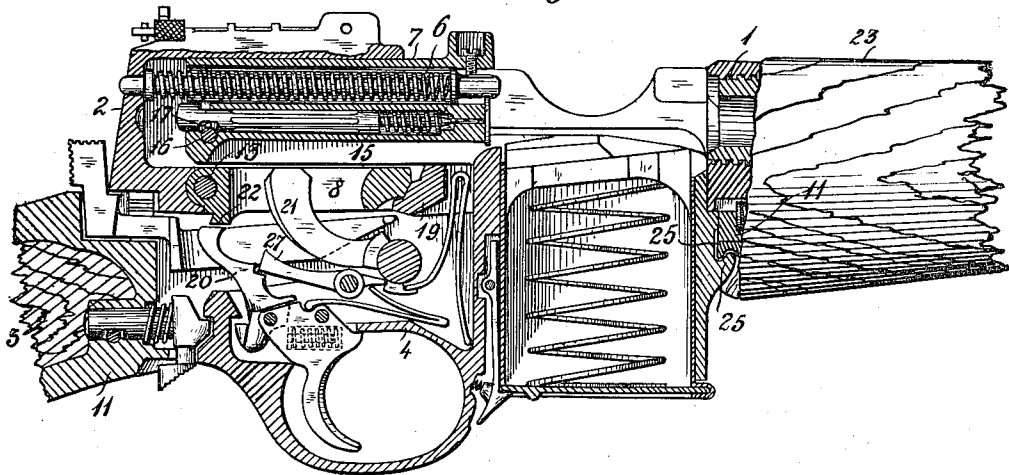

Witnesses:

*Judith Langlotz*  
*Geo. A. B. Puel*

Inventor:

*F. Ritter von Mannlicher*  
*by Wilkinson & Fisher*  
Attorneys.

No. 728,739.

PATENTED MAY 19, 1903.

F. RITTER VON MANNLICHER.  
AUTOMATIC FIREARM.

APPLICATION FILED DEC. 22, 1902.

NO MODEL.

2 SHEETS—SHEET 2.

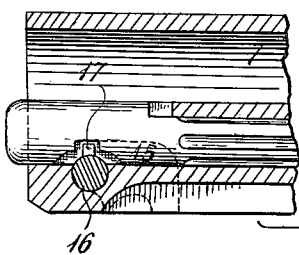
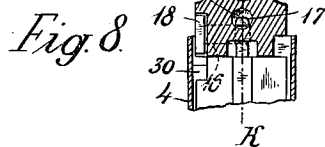
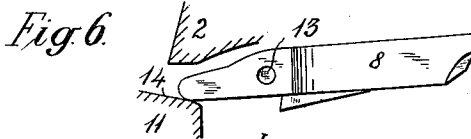
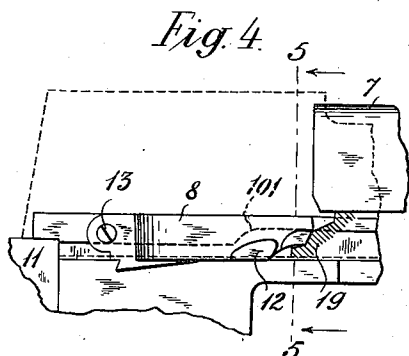
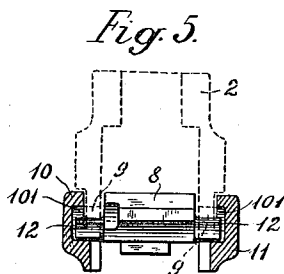
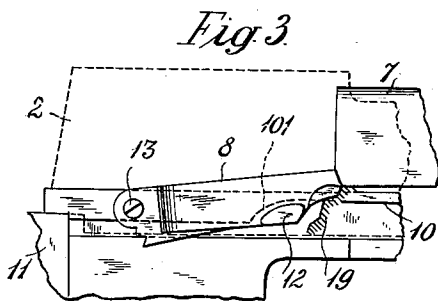

Fig. 9.

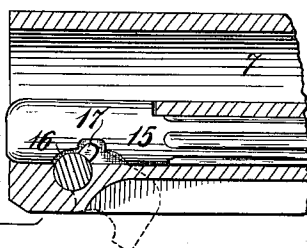
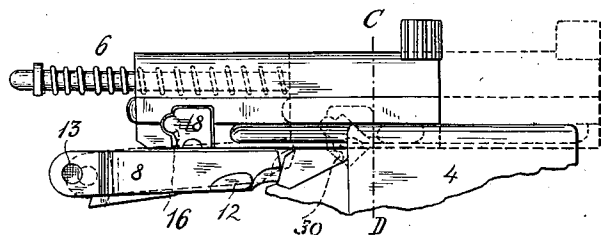

Fig. 7.



Witnesses.

*Judw. Engel*  
*Geo. A. Pique*

Inventor.

*F. Ritter von Mannlicher*

*By Wilkinson & Fisher*  
Attorneys

# UNITED STATES PATENT OFFICE.

FERDINAND RITTER VON MANNLICHER, OF VIENNA, AUSTRIA-HUNGARY.

## AUTOMATIC FIREARM.

SPECIFICATION forming part of Letters Patent No. 728,739, dated May 19, 1903.

Application filed December 22, 1902. Serial No. 136,262. (No model.)

*To all whom it may concern:*

Be it known that I, FERDINAND RITTER VON MANNLICHER, engineer, a subject of the Emperor of Austria-Hungary, residing at Vienna, in the Empire of Austria-Hungary, have invented certain new and useful Improvements in Small-Arms Having Automatic Breech Action; and I do hereby declare the following to be a full, clear, and exact description of the invention, such as will enable others skilled in the art to which it appertains to make and use the same.

This invention relates to improvements in that kind of automatic guns, rifles, and pistols and small-arms in general having a movable barrel, a breech-bolt closure, and a tumbler locking-bolt.

I will describe my improvements with reference to the accompanying drawings, in which—

Figure 1 is a vertical section through the breech-closing mechanism and the lock of a firearm according to the present invention, the breech being closed and locked. Fig. 2 is a similar view with the breech open. Figs. 3 and 4 are side elevations showing the tumbler locking-bolt in the locking and unlocking positions, respectively, the breech-casing being indicated in dotted lines and the front half of the fixed framing being omitted. Fig. 5 is a transverse vertical section along the line 5 5 of Fig. 4, parts being shown in elevation, looking from the barrel end, the breech-bolt and the bridge-piece being omitted, the framing being shown in section, and the breech-casing being indicated in dotted lines. Fig. 6 shows in side elevation a modification of the tumbler locking-bolt. Fig. 7 shows in side elevation, the breech-casing being omitted, the breech-bolt, together with the lever, for safe locking the firing-pin. Fig. 8 is a section on the line CD of Fig. 7 looking from the forward end of the breech-bolt, the firing-pin being omitted. Fig. 9 shows to an enlarged scale sections on the line IK of Fig. 8 through the rear end of the breech-bolt for the purpose of illustrating the two positions of the bolt for safety locking the firing-pin.

In firearms of this kind the barrel 1, together with the breech-casing 2, is capable of moving longitudinally against the pressure of a spring 5 in a framing 11, which is fixed

to the stock 3 and which carries the lock-casing, together with the magazine-box 4. After the shot is fired the barrel is moved by the recoil from the position shown in Fig. 1 back into the position shown in Fig. 2 and at first with the breech-bolt 7, while as soon as the barrel has been brought to rest by striking against the lock-casing the breech-bolt continues its motion by reason of its inertia in opposition to the pressure of a spring 6 until it also has assumed the position shown in Fig. 2. In this movement the breech-bolt was hitherto compelled to depress the tumbler locking-bolt by means of a beveled portion formed at its rear end, the said tumbler locking-bolt itself bearing with its underside on a beveled part on the upper side of a bridge-piece 19 in the lock-casing. The fact that the breech-bolt itself had to depress the tumbler locking-bolt in order to effect the unlocking was prejudicial to the secure and reliable action of the breech closing and locking mechanism. By the present invention this drawback is obviated by arranging that the unlocking of the breech-bolt shall be effected in a positive manner while the barrel moves back without the breech-bolt having to cooperate for this purpose, whereupon the breech-bolt is moved back into the open position by reason of its momentum. For this purpose the tumbler-bolt 8, as shown in Figs. 1, 3, 4, and 5, is provided with lateral projections or studs 12, which project through apertures 9 in the lower edge of the breech-casing and which engage under a guiding-rib 10 in the fixed framing 11, the said guiding-rib extending rearwardly at 101 with a downward inclination. Now when the barrel on recoil moves back with the breech-casing the studs 12 strike against the beveled end 101 of the guiding-rib 10, Fig. 4, whereby the tumbler-bolt is depressed, and thus without the cooperation of the breech-bolt slides down over the upper side of the bridge-piece 19 and unlocks the breech-bolt. The latter then moves back in the ordinary way into the open position. After this the breech-bolt 7 is shot forward again by the spring 6 in the well-known way. During this time the tumbler-bolt is held down by the breech-bolt 7, (that slides over it,) and thus bears with its forward end against the bridge-piece 19 in such

a manner that the spring 5 is unable to move forward the barrel with the breech-casing; but when the breech-bolt has again struck against the barrel and has thus released the  
 5 forward upper edge of the tumbler-bolt the spring 5 comes into operation. The barrel, with the breech-casing, then moves forward into the position shown in Fig. 1, and the  
 10 tumbler-bolt in sliding with its under side over the inclined upper side of the bridge-piece 19 is raised so that its forward end comes behind the rear end of the breech-piece and locks the latter, as shown at Fig. 1. The  
 15 same purpose may also be effected by extending the tumbler-bolt rearwardly beyond its pivot 13 and causing it to bear with its rear end upon an inclined guide 14 on the frame 11, as in Fig. 6. In this construction, as in  
 20 the previous one, during the rearward movement of the barrel the tumbler-bolt is turned with its forward end downward by the incline 14 for the purpose of unlocking without requiring the coöperation of the breech-bolt, which does not begin to move back until the  
 25 unlocking has been effected. The action in closing the breech-bolt and locking it is the same as in the construction shown in Figs. 1 to 5.

By means of the hereinbefore-described arrangement there is also gained the further  
 30 advantage that the forward end of the tumbler-bolt, which when the locking has been effected bears against the rear end of the breech-bolt 7, can be made with a curvature  
 35 concentric to the pivot 13, so that the rearward pressure of the breech-bolt is transmitted centrally through the concentric abutment of the tumbler-bolt to the pivot 13 and the fixed framing.

In the firearm herein described there is also provided a device for the purpose of preventing the firing-pin 15 from striking against the percussion-cap of the cartridge so long as the breech-bolt is not completely closed and  
 45 locked. This device consists in constructing the cross-bolt 16, which holds the firing-pin in its place in the breech-bolt 7, with a tappet or shoulder 17, that engages with a notch in the firing-pin, and also with a lever-arm 18  
 50 at one end thereof, as shown in Figs. 7, 8, and 9. This lever-arm is adapted to drop into a recess 30, Figs. 7 and 8, in the framing 11 or in the magazine-box when the breech has been closed and locked, as indicated in  
 55 dotted lines in Figs. 7 and 9 in right-hand position, while at other times the lever 18 bears on the tumbler-bolt or on a guide on the framing, as indicated in Fig. 7 in full lines, where-  
 60 by the tappet or projection 17 is held in a position turned toward the rear, as at Fig. 9, left-hand position. By this means even if the hammer 21 should strike against the firing-pin 15 the latter will be arrested by the pro-  
 65 jection 17 before its point can reach the detonator, because the lever 18 is prevented from turning downward, and consequently the projection 17 is locked in the backward

position shown at the left hand of Fig. 9; but when the breech-bolt is closed and locked and the hammer strikes against the firing-pin the  
 70 latter will be free to shoot forward and fire the detonator, because the lever 18 is able to drop into the recess, and therefore the projection 17 is able to give way to the firing-pin.

According to another improvement there  
 75 is provided a device by means of which the releasing of the hammer is prevented so long as the breech-bolt is not closed and locked. This device consists in forming the known  
 80 detent-lever 20, which is pivoted to the trigger and serves to release the hammer-sear 27, with an upward extension, whose upper end faces a shoulder 22 on the tumbler-bolt or  
 85 breech-casing. The position of this shoulder 22 is such that it will be situated over the upper end of the lever 20 so long as the tumbler-bolt or the breech-casing is in the open  
 90 position shown in Fig. 2 and will therefore prevent the lever 20 from rising, and consequently the hammer from being released; but when the breech is closed and locked, as shown  
 95 in Fig. 1, then the upper end of the lever 20 is clear of the projection 22, so that the lever 20 is free to rise when the trigger is pulled, and as it slides past the rear edge of the projection 22 it will also be pressed back slightly  
 100 as it slides along the rear edge of the projection 22. Thus by the upward movement of the lever 20 the sear is lifted in the usual way out of the cocking-notch of the hammer  
 105 21, so as to release the same, and at the same time the lever 20 is pressed back for a short distance under the rear end of the sear. When the sear has been lifted out of the  
 110 cocking-notch of the hammer, the lever 20 is turned farther back by continued pressure on the trigger into the position indicated by dotted lines in Fig. 1, so as to allow the sear 27  
 115 to return to the position shown in Fig. 2 without being hindered by lever 20 in the cocking operation which takes place during the opening of the breech-closure.

In consequence of the backward movement of lever 20 when it is acted upon by the rear  
 115 edge of the projection 22 the distance through which it has to be moved rearward by the trigger after it has arrived in the highest position is diminished, and thereby the pulling of the trigger is facilitated. If the trigger be  
 120 then released, the sear-notch in lever 20 will engage smoothly with the sear 27, and the firearm is again ready for firing.

The two devices last described serve to afford a double security against premature firing, because, first, the releasing of the ham-  
 125 mer itself is prevented, and, secondly, even if such should take place the firing-pin will not reach the detonator.

The barrel is inclosed in a wooden front stock-23 in such a manner that it is movable  
 130 longitudinally in the same, so that this front stock can be fixed to the framing 11 without hindering the longitudinal movements of the barrel.

For the purpose of fixing the front stock 23 to the framing 11 there is fixed in the former an iron plate 24, Figs. 1 and 2, which carries at its rear end a nose 25, which when inserted into the magazine-box and the lock-casing 4 are engaged with a hook 26 on the casing, so that the said plate, and with it the front stock, are secured thereby against longitudinal movement relatively to the magazine-box and the framing 11. The other parts of the firearm are of known construction and need not be further described.

I claim—

1. In an automatic small-arm the combination with the breech-casing, the barrel secured thereto, a tumbler locking-bolt pivoted in the breech-casing, a breech-bolt adapted to slide longitudinally in the breech-casing and a bridge-piece in the fixed framing adapted to support the front end of the tumbler locking-bolt, the said tumbler locking-bolt being adapted to come into and out of engagement with the rear end of the said breech-bolt: of a guide or guides in the fixed framing inclined to the path of the breech-casing, and a projection or projections on the tumbler locking-bolt engaging with such guide or guides, substantially as and for the purpose described.

2. In an automatic small-arm the combination with the fixed framing, the breech-casing, the barrel secured thereto and adapted to slide longitudinally in the fixed framing

the breech-bolt adapted to slide longitudinally in the breech-casing, a firing-pin adapted to move longitudinally in the breech-bolt, a hammer adapted to strike against the rear end of the firing-pin, a hammer-sear, a trigger and a detent-lever pivoted to the trigger and adapted to engage with the hammer-sear: of an abutment located on a part moving along with the breech-casing in front of the outer end of such detent-lever and adapted to be struck by the free end of such detent-lever at any position of the breech-casing except the outermost forward one, substantially as and for the purpose described.

3. A hammer adapted to strike against the rear end of the firing-pin, a hammer-sear, a trigger and a detent-lever pivoted to the trigger and adapted to engage with the hammer-sear: of an abutment on the tumbler locking-bolt pivoted in the breech-casing, such abutment being located in front of the outer end of such detent-lever and adapted to be struck by the free end of such detent-lever at any position of the breech-casing except the outermost forward one substantially as and for the purpose described.

In testimony whereof I affix my signature in presence of two witnesses.

FERDINAND RITTER VON MANNLICHER.

Witnesses:

JOHN GEORGE HARDY,  
C. B. HURST.