

May 16, 1944.

P. DE KIRÁLY ET AL

2,348,790

BREECH MECHANISM FOR AUTOMATIC FIREARMS

Filed Nov. 13, 1939

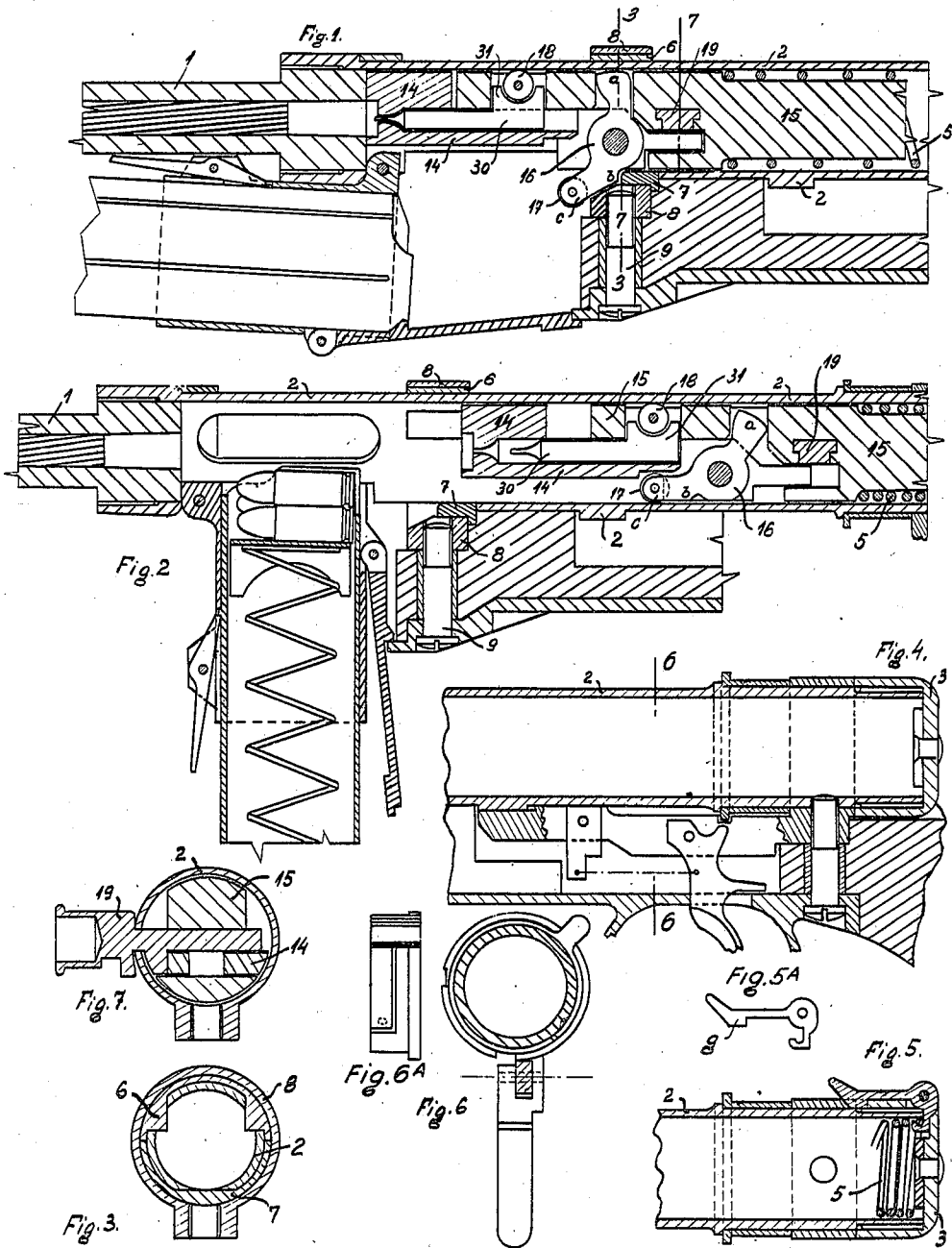

Inventors:
Paul de Király
László Lőrincz
By *[Signature]*
Theri Attn.

UNITED STATES PATENT OFFICE

2,348,790

BREECH MECHANISM FOR AUTOMATIC FIREARMS

Paul de Király and József Kucher, Budapest, Hungary; vested in the Alien Property Custodian

Application November 13, 1939, Serial No. 304,226
In Hungary December 12, 1938

1 Claim. (Cl. 42—3)

This invention relates to automatic firearms of the kind wherein the bolt is operated by the cartridge shell recoiling under the pressure of the powder gases, after having overcome the inertia of the bolt, and wherein, in order to increase the inertia of the bolt and thus prevent premature opening of the same, the bolt comprises two members connected by a lever herein-after referred to as an "accelerator lever" having two arms of different lengths, the lever being pivoted on the bolt proper, its longer arm loosely connected to the inertia member of the bolt, the shorter arm engaging a stationary abutment in the breech casing of the arm, thus imparting, under pressure of the cartridge shell, to the inertia member relative movement at increased velocity.

The present invention comprises an improved construction of such bolt mechanism, according to which the two armed accelerator lever, adapted for retaining without any additional component parts, itself and the two members of the bolt in their unlocked relative position during the recoil and return movement of the bolt, reduces at the same time the pressure and friction between the inertia lever and the breech casing, caused by the pressure of the closing spring.

The invention also comprises means for lessening friction between the moving parts, during their rearward and forward travel, and their guide, that is the breech casing, caused by the tendency of the return spring to rotate the inertia lever into its initial locked position, thus causing lateral pressures on the walls of the receiver. One embodiment of the invention is illustrated in the accompanying drawing, in which

Fig. 1 is a longitudinal section through the bolt in its closed position,

Fig. 2 is a longitudinal section through the bolt during its rearward movement,

Fig. 3 is a cross sectional view on the line 3—3 of Fig. 1 taken through the straight guide of the bolt and through the abutment of the inertia lever,

Fig. 4 is a cross section, showing the seat of the handle in the striker.

Fig. 5 shows means for locking the cap of the breech-casing to the latter, by means of a lever controlled by the recoil spring.

Fig. 5A illustrates a detail of the device shown in Fig. 5.

Fig. 6 is a sectional view taken on the line 6—6 of Fig. 4 showing the fire-control ring mounted on the breech-casing and its spring pawl, cut out from the body of the fire-control ring.

Fig. 6A is a side view of the device shown in Fig. 6.

Fig. 7 is a cross sectional view on the line 7—7 of Fig. 4 taken through breech-casing, bolt, striker and handle, showing the manner in which the handle sits in the striker and is guided in the breech-casing.

The barrel 1 is firmly connected, by a screw-thread to the breech casing 2 comprising a hollow cylinder, the rear of which is closed by a cap.

Behind the magazine and ejection openings, and close to them, an inverted U shaped part 6 sits on the breech casing, its flanges passing through the wall of the same and forming the straight guide for the bolt. Below this straight guide 6 is arranged in a cut in the lower wall of the breech casing the abutment 7 of the accelerator lever. The straight guide 6 and abutment 7 are held in their position by the ring 8 encircling both parts and being connected by the screw 9 to the trigger plate.

In the cylindrical interior of the breech casing is placed the breech bolt of the non-rigidly locked type which supports the bottom of the cartridge shell mostly by its inertia and which in the usual way is allowed a rectilinear movement of suitable length relatively to the breech casing and is controlled by the main spring 5.

The breech bolt consists of three parts; the bolt proper 14 and striker 15 which are connected by the accelerator lever 16 pivoted in the rear end of the bolt 14.

The principle of this main lever is known from other inventions (see British Specification No. 26,783 A. D. 1912). The two armed inertia lever is pivoted in the rear part of the bolt 14. Its short arm *b* projects downward from the bolt whilst its long arm *a* is in loose connection with the striker. When the bolt 14 moves backward under the pressure of the powder gases, the lower, short arm of the inertia lever hits the abutment 7, whereupon its long arm pushes back with increased velocity the striker 15 relatively to the bolt 14.

Accordingly, the weight of the striker asserts itself more effectively than if the striker moved only with the speed of the breech bolt, in proportion to the existing leverage, or the proportion in which stand the lengths of both arms of the two armed inertia or locking lever.

In other inventions of this kind of breech bolt mechanism either the striker and the inertia lever are held in their unlocked or in their locked positions by some separate spring controlled sear,

or, alternatively, the striker and the inertia lever are allowed to return into their unlocked positions relatively to the bolt proper and because then, in the last phase of their return movement the lower, short arm of the inertia lever would run up against the abutment in the breech casing, this abutment of the inertia lever is adapted for moving out of the way of the lower arm of the inertia lever during the return movement of the latter.

In our invention we avoid this complication by giving a third arm *c* to the inertia lever, which can be called an extension of the short arm *b*. This third arm *c* of the inertia lever is adapted for keeping the inertia lever 16 and with it the striker 15 during the repeating movement of the bolt, in their cocked position, by the end of this arm *c* sliding on the wall of the breech casing and thus hindering any forward rotation of the inertia lever, until the arm *c* on its return way has passed the abutment 7.

The longer is the extension *c*, the less is its pressure on the wall of the breech casing. A convenient length of the extension *c* is chosen (Figs. 1 and 2) at which this pressure remains within convenient limits.

Considering that the main spring 5 constantly strives during the recoiling and return movement of the bolt to cause forward rotation of the inertia lever 16 so that the extension *c* of its short arm *b* is constantly pressed against the wall of the breech casing, thus causing undesired friction, we arrange in the end of the extension *c* of the arm *b* of the inertia lever 16 a roller 17 in order to avoid the undesired friction.

Another source of undesired friction is the fact that the same force which presses against the wall of the breech casing the end of the extension *c* of the arm *b* of the inertia lever, strives to lift the pivot of the accelerator lever, thus pressing the bolt and the striker against the upper wall of the breech casing 2. Another undesired friction is thus caused which also must be eliminated as far as possible. We accomplish this by employing another roller 18, sitting in the top of the striker, preferably near to its forward end and approximately above the roller 17 in the extension *c* of the arm *b* of the accelerator lever 16, when in its cocked position.

Thus, when the pressure of the powder gases forces the bolt backward, the main lever 16 pushes back the striker 15 into its cocked position and keeps it there, without the help of other parts, during the whole subsequent backward and forward movement of the bolt.

When, toward the end of its forward movement the extension *c* of the arm *b* of the inertia lever has passed the abutment 7, the inertia lever 16 is

allowed to rotate forward under the pressure of the main spring 5 the striker advances and fires the cartridge in the barrel.

A handle 19 is connected with the striker, being passed therethrough.

The trigger mechanism may be of the conventional design.

The firing pin 30 is inserted between bolt 14 and striker 15 and held in correct position by its wing 31, fitting into the recess in which sits the roller 18 of the striker 15. This disposition allows very easy change of the firing pin in case of damage.

Having now particularly described and ascertained the nature of our said invention and in what manner the same is to be performed, we declare that what we claim is:

An automatic firearm comprising a casing, a barrel secured to said casing, a breech movable in said casing, said breech comprising a supporting element adapted to perform a recoil movement, a two-armed lever pivotally mounted on said supporting element, an actuating element movably disposed in said casing, the first arm of said lever being disposed in contact with said actuating element, resilient means urging said actuating element against said supporting element in a direction opposite to that of the recoil movement thereof, an abutment adapted to engage the second arm of said lever and tilt the same, whereby said actuating element is a displaced relative to said supporting element, a control member forming an extension of said second arm, guiding means adapted to engage said control member to maintain said lever in tilted position during the recoil movement, a firing pin operatively connected to said actuating element, whereby upon the return movement of the breech, said lever after clearing said guiding means, is suddenly thrown forward under the influence of said resilient means to restore the original relative position between said supporting element and actuating element, whereby the firing pin is suddenly projected with respect to said supporting element, a second guiding means of inverted U-shape, said casing being provided with an opening, said U-shaped second guiding means being secured to the outside of said casing, the prongs of said U-shaped second guiding means projecting through said opening into the casing and serving to guide said actuating element: said abutment being provided with flaps extending outside said casing, and a ring member encircling the outside part of said U-shaped second guiding means and said flaps, and securing the same to said casing.

PAUL DE KIRÁLY.
JÓZSEF KUCHER.