

F. VON MANNLICHER, DEC'D.

C. VON MANNLICHER, ADMINISTRATRIX.

SMALL ARMS HAVING AUTOMATIC BREECH ACTION.

APPLICATION FILED FEB. 23, 1904.

5 SHEETS—SHEET 1.

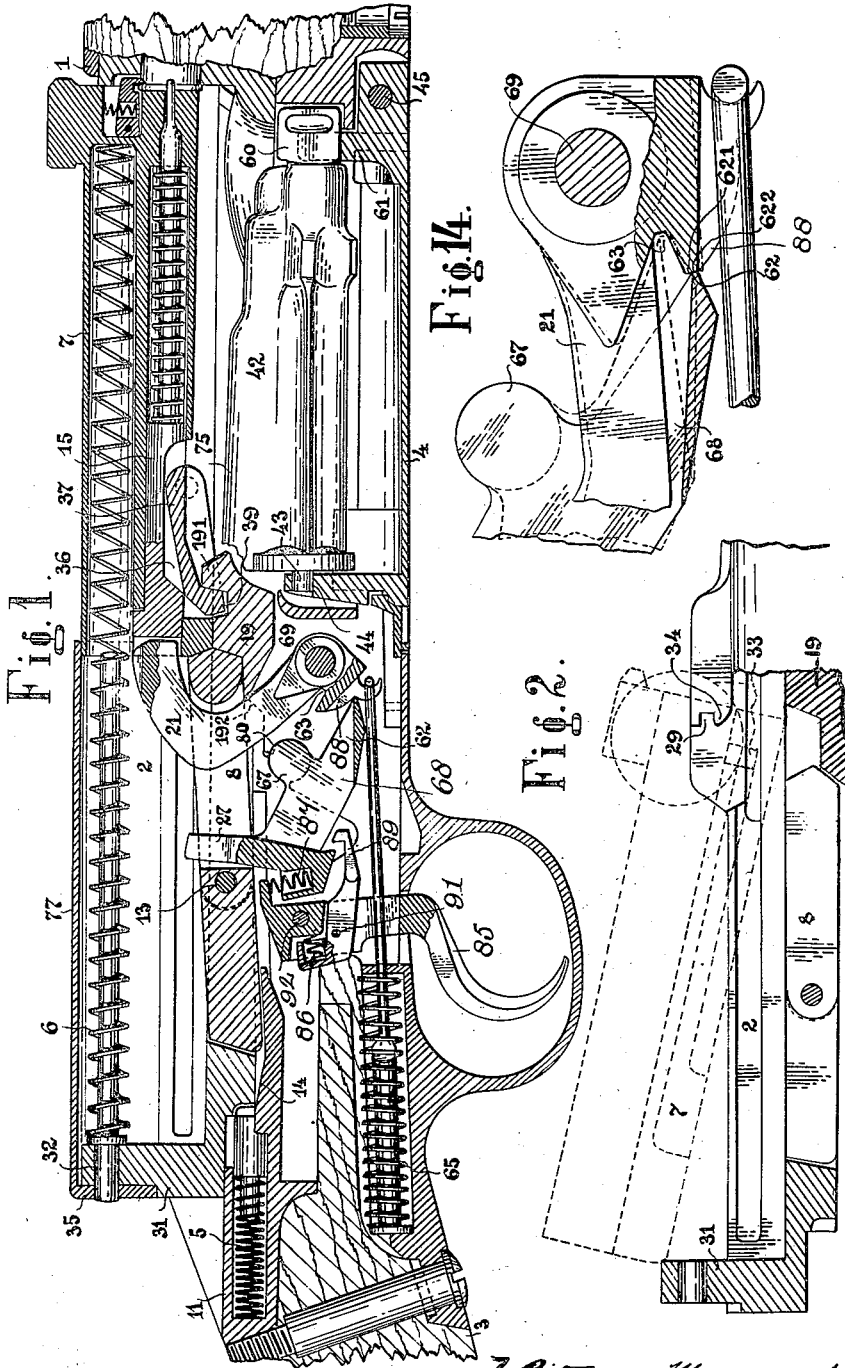

Witnesses  
 W. Max. Small  
 Geo. H. Deuce.

F. Ritter von Mannlicher, dec'd. Inventor.  
 C. von Mannlicher, Admstr.,  
 by Millinson & Fisher,  
 Attorneys.

No. 804,748.

PATENTED NOV. 14, 1905.

F. VON MANNLICHER, DEC'D.

G. VON MANNLICHER, ADMINISTRATRIX.

SMALL ARMS HAVING AUTOMATIC BREECH ACTION.

APPLICATION FILED FEB. 23, 1904.

6 SHEETS—SHEET 2.

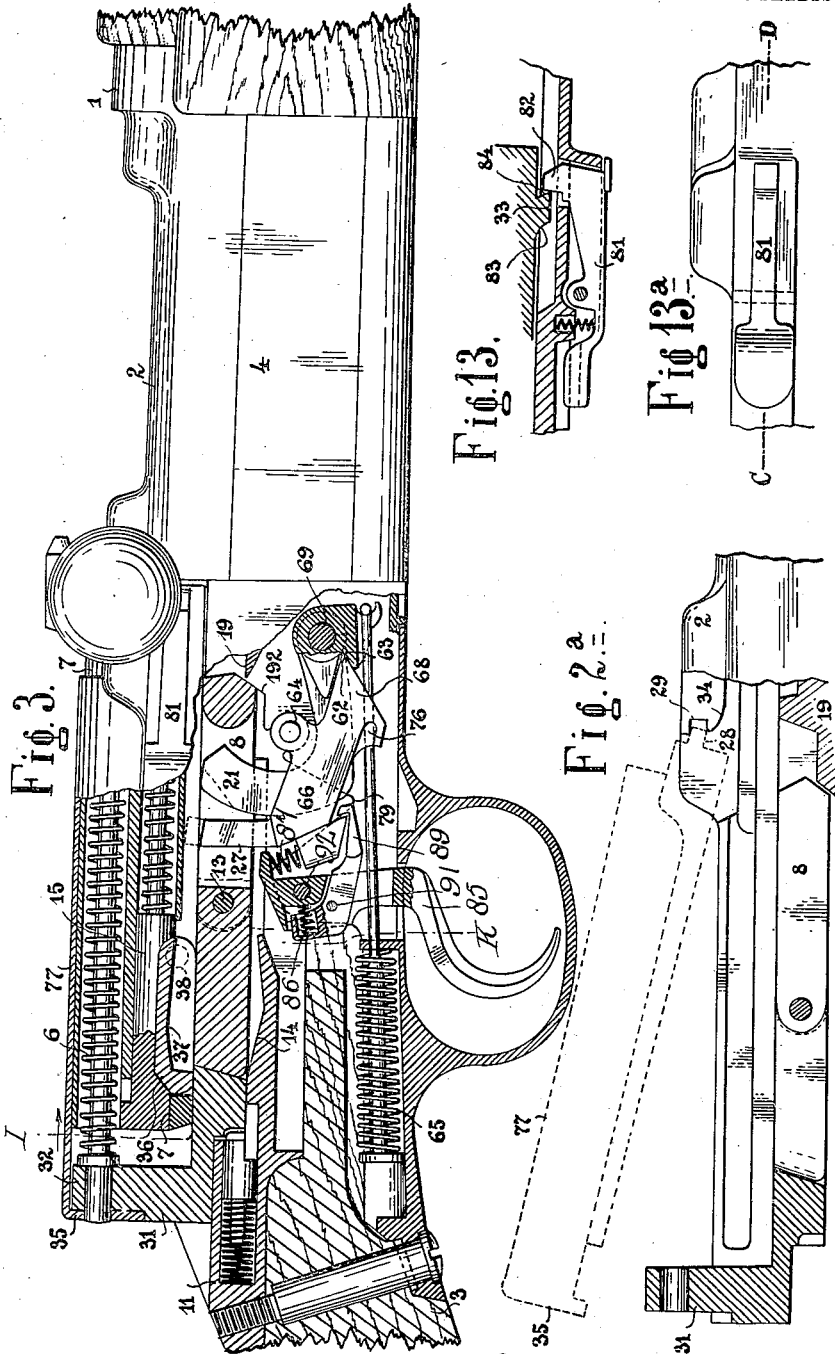

Witnesses  
 W. Mar. Duvall  
 Geo. H. Bepue.

F. Ritter von Mannlicher, deceased Director,  
 G. von Mannlicher, Adms.,  
 by Milkinson & Fisher,  
 Attorneys.

F. VON MANNLICHER, DEC'D.

C. VON MANNLICHER, ADMINISTRATRIX.

SMALL ARMS HAVING AUTOMATIC BREECH ACTION.

APPLICATION FILED FEB. 23, 1904.

5 SHEETS—SHEET 3.

Fig. 10.

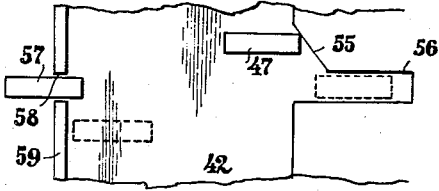

Fig. 4.

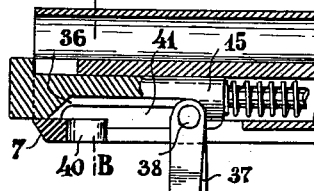

Fig. 11.

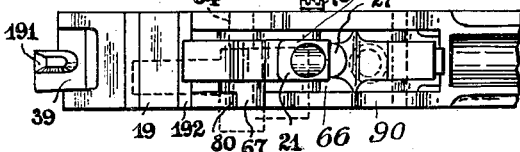

Fig. 5.

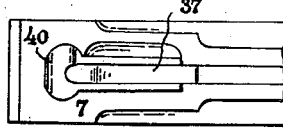

Fig. 12.

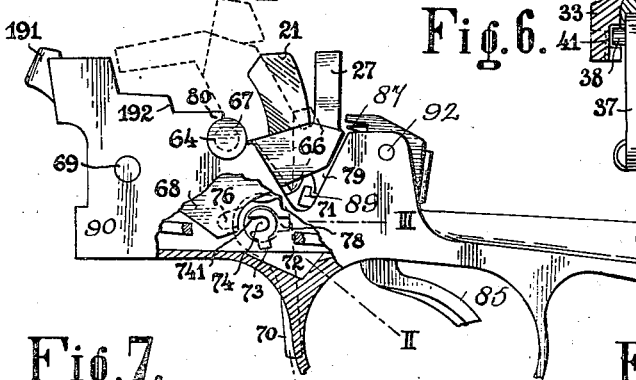

Fig. 6.

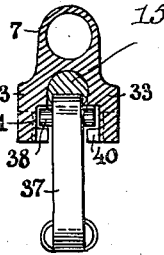

Fig. 7.

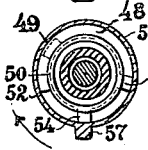

Fig. 9.

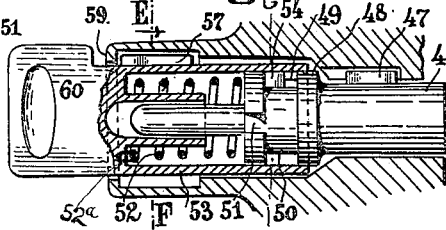
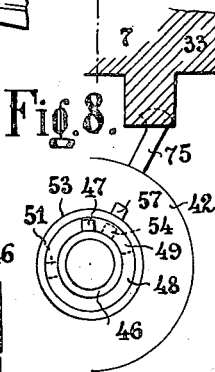

Fig. 8.



Witnesses.

Mr. Max Small  
Geo. H. Bepue.

F. Ritter von Mannlicher, dec'd, Inventor.  
C. von Mannlicher, Adm.  
by Wilkinson & Fisher,  
Attorneys.

F. VON MANNLICHER, DEC'D.  
G. VON MANNLICHER, ADMINISTRATRIX.

SMALL ARMS HAVING AUTOMATIC BREECH ACTION.

APPLICATION FILED FEB. 23, 1904.

5 SHEETS—SHEET 4.

Fig. 16.

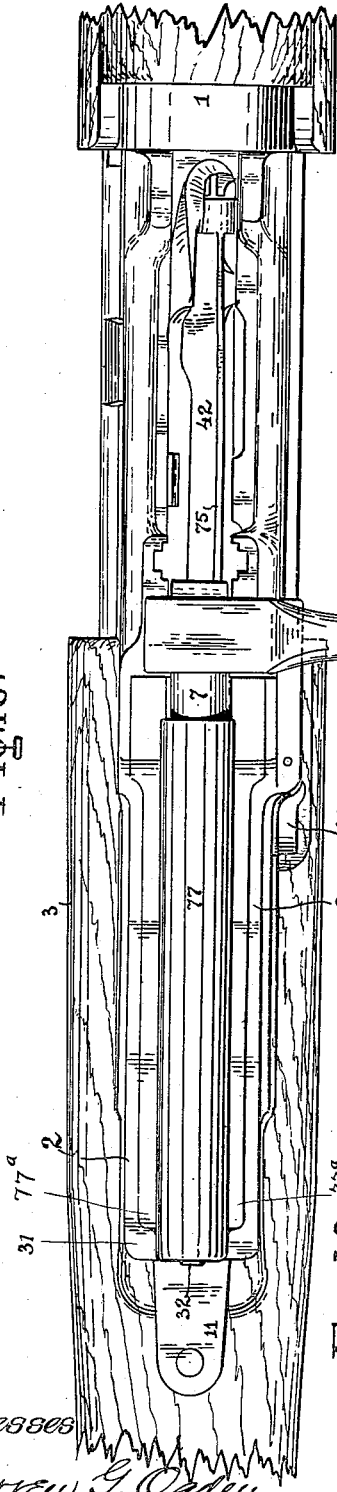

Fig. 17^a.

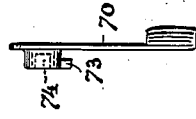

Fig. 17.

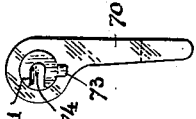

Fig. 15.

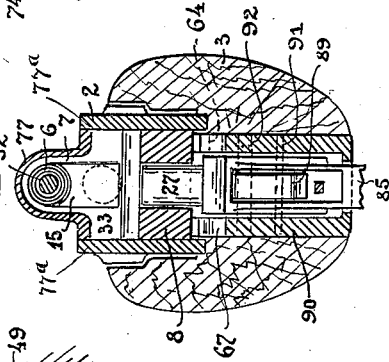

Fig. 8^a.

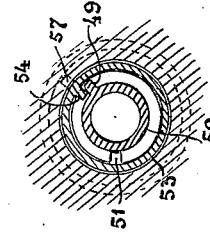
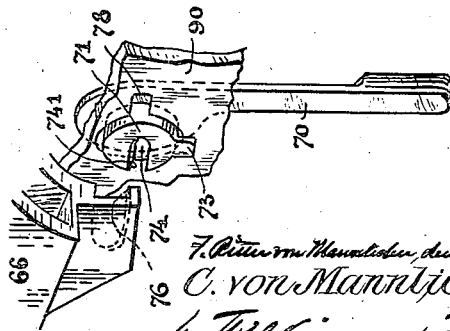

Fig. 18.



Witnesses  
Warren G. Ogden  
Geo. A. Demme.

F. Ritter von Mannlicher, dec'd. Inventor.  
C. von Mannlicher, Admin.  
by Wilkinson & Fisher  
Attorneys.

F. VON MANNLICHER, DEC'D.  
C. VON MANNLICHER, ADMINISTRATRIX.

SMALL ARMS HAVING AUTOMATIC BREECH ACTION.

APPLICATION FILED FEB. 23, 1904.

5 SHEETS—SHEET 5.

Fig. 14<sup>b</sup>.

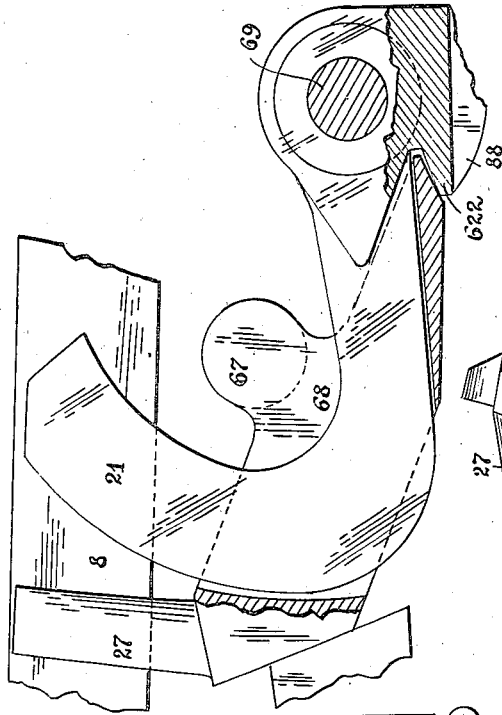
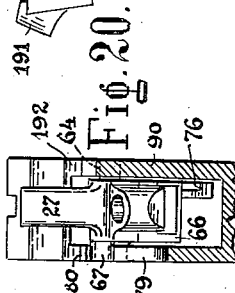
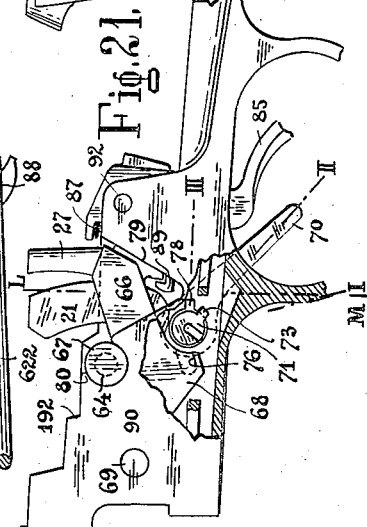
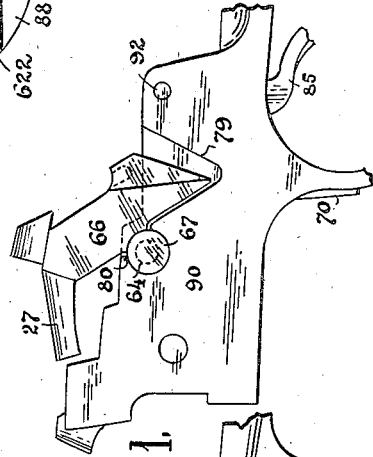
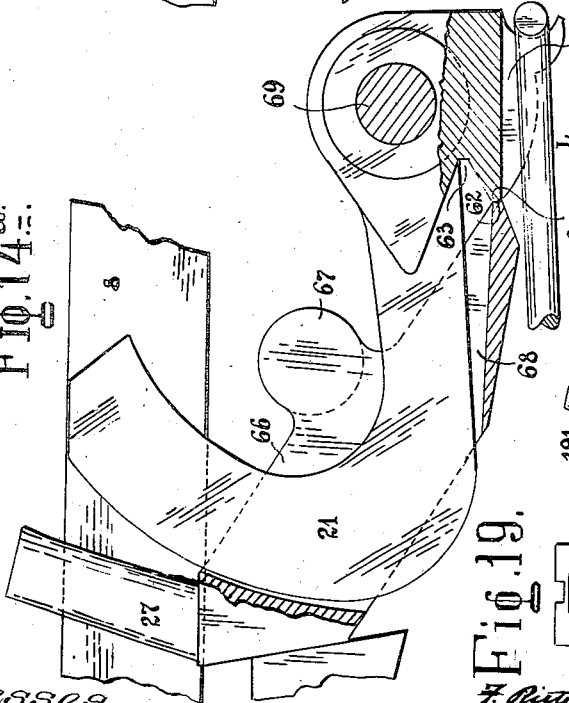

Fig. 14<sup>a</sup>.



Witnesses  
Lawrence G. Ogden  
Geo. A. Payne

Fig. 19.  
F. Ritter von Mannlicher, dekl. Inventor.  
C. von Mannlicher,  
Admin.  
By William & Fisher  
Attorneys

# UNITED STATES PATENT OFFICE.

CÄCILIE VON MANNLICHER, OF VIENNA, AUSTRIA-HUNGARY, ADMINIS-  
TRATRIX OF FERDINAND VON MANNLICHER, DECEASED.

## SMALL-ARM HAVING AUTOMATIC BREECH-ACTION.

No. 804,748.

Specification of Letters Patent.

Patented Nov. 14, 1905.

Application filed February 23, 1904. Serial No. 195,504.

*To all whom it may concern:*

Be it known that FERDINAND RITTER VON MANNLICHER, deceased, late a subject of the Emperor of Austria-Hungary, and a resident of Vienna, Empire of Austria-Hungary, did invent certain new and useful Improvements in Small-Arms Having Automatic Breech-Actions and Sliding Barrels, of which the following is a full, clear, and exact description, such as will enable others skilled in the art to which it appertains to make and use the same.

This invention relates to improvements in small-arms having automatic breech-action such as described in Ferdinand Ritter von Mannlicher's former patent, No. 728,739, and has for its object to simplify and otherwise improve the construction and to facilitate the taking apart and putting together the various parts of such arms for rendering such arms perfectly suitable as a service-gun for infantry.

In the accompanying drawings, Figure 1 is a longitudinal sectional elevation of the improved gun, parts of the same being broken away and others being shown in elevation, all the parts being in the position which they occupy at the moment of firing. Figs. 2 and 2<sup>a</sup> show a part of the breech-casing in section for illustrating the putting in and taking out of the breech-bolt and its covering-cap. Fig. 3 is a side elevation, partly in section, of the gun with the parts in the position which they occupy when the breech is open. Figs. 4, 5, and 6 show a longitudinal section, a bottom view, and a transverse section on the line A B, Fig. 4, respectively, of the rear portion of the breech-bolt for illustrating a safety-lock for the firing-pin. Fig. 7 is a section on the lines E F, Fig. 9, the drum being omitted, viewed in the direction of the arrow. Fig. 8 is an end view. Fig. 8<sup>a</sup> is a section on line G H, Fig. 9, viewed in a direction opposite to that indicated by the arrow, Fig. 9; and Fig. 9, a longitudinal section illustrating the construction of the spindle of the magazine-drum. In Fig. 8 also the outlines of this drum and part of the breech-bolt (in transverse section through its front end) are indicated. Fig. 10 shows part of the inner surface of the bore in the drum spread out in a plane. Figs. 7 to 10, inclusive, are drawn on a larger scale than the preceding ones, and in Figs. 7 and 8 the parts are shown in different positions. Fig. 11 is a plan view of the lock of the gun and its casing, and Fig. 12 an elevation of the same as

viewed from the left side of the gun. Fig. 13<sup>a</sup> is a side elevation of a part of the breech-casing, and Fig. 13 is a section on the line C D, Fig. 13<sup>a</sup>. Fig. 14 is a side elevation, partly in section, showing the action of the sear. Figs. 14<sup>a</sup> and 14<sup>b</sup> show the parts illustrated by Fig. 14 in two different positions separately. Fig. 15 is a section on line I K, Fig. 3. Fig. 16 is a plan view of the arm in the position of the parts shown in Fig. 3. Figs. 17 and 17<sup>a</sup> show the locking-lever for the sear in front and side elevation. Fig. 18 shows a perspective view of the head of the locking-lever, together with a part of the sear, the wall of the lock-casing being partly broken away. Fig. 19 is a rear elevation of the sear, the lock-casing being shown in section on line L M, Fig. 20. Fig. 20 is a side elevation of the lock similar to Fig. 12, but with the locking-lever in another position, part of the wall of the lock-casing being broken away. Fig. 21 is a similar view showing the sear in the lock-casing in a position ready for removal.

In guns of that class to which the present improvements are applicable the breech-casing 2 is secured to the barrel 1 and the breech-bolt 7 is adapted to slide longitudinally in the breech-casing.

6 is a spring tending to hold the breech-bolt in closing position with its front end against the rear end of the barrel, such spring bearing with its rear end against the rear wall 31 of the breech-casing and with its front end against the breech-block 7.

8 is a tumbler-locking bolt pivoted at 13 in the breech-casing 2 and abutting in the locking position with its front end against the bottom of the rear end of the breech-bolt 7, as shown in Fig. 1.

The barrel, together with the breech-casing and the tumbler-locking bolt, are adapted to slide longitudinally in a frame 11, carrying the lock-casing and the magazine-casing 4 and secured to the butt 3 of the gun, and 5 is a spring tending to hold the breech-casing, together with the barrel, in the forward position shown in Fig. 1.

On firing the gun the barrel, together with the breech-casing and the tumbler-locking bolt, recoils, sliding in the frame 11 against the action of the spring 5. At the beginning of the recoil the tumbler-locking bolt is in engagement with the breech-bolt, thus holding the breech closed; but during the first

part of the recoil the rear end of the tumbler-locking bolt 8, extending beyond its fulcrum 13, slides over an incline 14 in the fixed frame 11. The front end of the tumbler-locking bolt is thus depressed, and the breech-bolt 7 is unlocked at the moment when the barrel strikes against and is arrested by a stop (not shown) in the fixed frame. The breech-bolt then continues its rearward movement (owing to the momentum acquired in the above-mentioned first part of the recoil) against the action of a spring 6. In so doing the breech-bolt extracts the empty cartridge-shell from the barrel until the bottom of the shell strikes against the ejector 191, fixed to the lock-casing, whereby this shell is ejected. During this rearward movement of the barrel and the breech-bolt the hammer 21 is cocked, the rear end of the breech-bolt forcing back the hammer-head. After the breech-bolt has reached the end of its rearward stroke (limited by a stop not shown) it is thrown forward by the spring 6, and by this movement it pushes a fresh cartridge from the magazine into the barrel, which during this movement is held in its rearmost position, since the tumbler-locking bolt 8 bears with its front end against the incline 192 of the bridge-piece 19 on the lock-casing and is prevented from rising by the breech-bolt sliding along its top side. When the breech-bolt strikes against the rear end of the barrel, the spring 5 is free to act and pushes forward the barrel, together with the breech-bolt, so that the front end of the tumbler-locking bolt slides upward along the incline 192 on the bridge-piece 19 and coming against the rear end of the breech-bolt locks the latter. The gun may then be fired, and the operations described will be repeated as long as there are fresh cartridges in the magazine.

The general construction and operation of the gun just described presents no essential novelty over those described in Ferdinand Ritter von Mannlicher's prior patent, No. 728,739.

For preventing dust, &c., from entering into the breech-casing a cap 77 is provided with projections 28 at its front end which engage into notches 29 at the inner side of the breech-casing side walls and, further, provided with a head-plate 35 at its rear end, which is adapted to overlap the rear head-plate 31 of the breech-casing. The guide-bolt 32 of the breech-bolt spring 6 enters through a hole in the head-plate 31 into a hole in the head-plate 35, so that the cap 77 is firmly held in position on the breech-casing. This cap is provided with lateral ribs 77<sup>a</sup>, the rear ends of which abut against the front side of the rear head-plate 31, as shown in Fig. 16. When it is desired to remove the cap 77, the rear end of the guide-bolt 32 is pressed inward, say, by the point of the projectile of a cartridge, so that this bolt comes out of engagement with

the hole in the head-plate 35. The rear end of the cap 77 may then be raised, as indicated in dotted lines in Fig. 2<sup>a</sup>, and the cap withdrawn rearwardly until the projections 28 come out of engagement with the notches 29, when the cap may be entirely removed. The breech-bolt is provided at both sides with longitudinal guide-ribs 33, adapted to engage under corresponding guide-ribs 34 at both sides of the breech-casing. The bottom side of the rear end of the guide-ribs 34 in the breech-casing is inclined or beveled upwardly, as shown in Figs. 2 and 2<sup>a</sup>, and the distance between the rear end of these guide-ribs 34 and the rear head-plate 31 of the breech-casing is slightly smaller than the distance between the front end of the guide-ribs 33 on the breech-bolt and the rear end of the latter. In order to remove the breech-bolt from the breech-casing after the cap 77 has been removed, as above described, and the breech-bolt being in the foremost position shown in Fig. 1, the guide-bolt 32 is pulled or pushed forward until it comes out of engagement with the hole in the head-plate 31, and then it is raised so that it can be withdrawn rearwardly, together with the spring 6. Then the breech-bolt is drawn back as in opening the breech (in being so moved it comes out of engagement with the tumbler-locking bolt 8, as above set forth) until the rear end of the breech-bolt abuts against the head-plate 31 and the front ends of the guide-ribs 33 at both sides of the breech-bolt have arrived under the beveled rear ends of the guide-ribs 34 at both sides of the breech-casing. The rear end of the breech-bolt is then raised, the inclination of the bottom sides of the rear ends of the ribs 34 permitting it to be so moved until it comes clear of the rear head-plate 31 of the breech-casing, as indicated in dotted lines in Fig. 2, and then the breech-bolt may be removed by simply drawing it rearward. For mounting those parts in position it is only necessary to repeat the above manipulations just described in the reverse order, taking care, however, that when the breech-bolt is inserted into the breech-casing the barrel is in its rearmost and the tumbler-locking bolt in its lowest or unlocking position, as otherwise the guide-ribs 33 cannot be pushed under the rear ends of the guide-ribs 34. By these means the cap 77 and the breech-bolt may be easily removed for inspection, cleaning, and repair and then mounted in position again.

In order to prevent the gun from being fired as long as the breech is not completely closed and the breech-bolt securely locked, at the bottom side of the firing-pin 15, guided longitudinally in the breech-bolt, as usual, a recess is provided, the rear end of which is inclined, as shown at 36. In the breech-bolt a locking-dog 37 is pivoted by means of trunnions 38, which dog is so shaped that its top

side lies snugly in the said recess when its bottom side lies snugly on the bottom of the breech-casing, and is thereby held flush with the bottom side of the breech-bolt, as shown in Fig. 3. When in this position of the parts the hammer 21 strikes against the rear end of the firing-pin 15, the latter cannot move forward in the breech-bolt, because it is held in position by the locking-dog 37, which in turn is prevented from giving way in a downward direction by the bottom of the breech-casing; but when the breech-bolt and the barrel are in the extreme forward position, (shown in Fig. 1,) in which the breech is completely closed and the breech-bolt locked by the tumbler-locking bolt 8, the rear end of the locking-dog 37 is opposite a recess 39 in the stationary bridge-piece 19, Figs. 1 and 11. When in this position of the parts the hammer strikes against the rear end of the firing-pin, the latter will be thrown forward, pushing down by the incline 36 the rear end of the locking-dog into the recess 39, and thus the gun will be fired. In the first part of the recoil movement of the barrel and the breech-bolt the rear end of the locking-dog slides over the inclined rear wall of the recess 39, and thus the locking-dog will be returned into its normal or locking position.

For facilitating the insertion and removal of the locking-dog into and out of the breech-bolt the rear end 40 of the recess provided in the breech-bolt for receiving the locking-dog is so large that the front end of this dog, together with its trunnions 38, may be freely inserted from below into this enlargement 40. (See Figs. 4, 5, and 6.) After the firing-pin 15 has been introduced into the breech-bolt the locking-dog is inserted into the enlargement 40 front end foremost, so that the trunnions 38 enter into grooves 31, extending from the enlargement 40 toward the front end of the recess. The locking-dog is then pushed forward, its trunnions being guided in the grooves 41 until they arrive at the front ends of the latter, the firing-pin moving along with the locking-dog against the action of its spring, and then the rear end of the locking-dog is turned upward into the enlargement 40, so that the top side of the locking-dog lies snugly in the recess in the firing-pin and its rear end against the incline 36, as shown in Fig. 3. Thus the firing-pin and the locking-dog are firmly held in position in the breech-bolt without the use of any screws or the like and may be readily removed and inserted again.

In this improved gun a drum-magazine is employed in which the drum 42 is provided at its rear end with a round journal-pin 43, working in a bearing 44 at the bottom of the magazine-casing, which bottom is pivoted on the fixed pin 45 in the usual manner. The front end of the drum is bored out for receiving a spindle 46, Figs. 7 to 10, provided

with a key 47, adapted to engage into a key-groove in the drum, so that the drum must turn with the spindle. The latter is, moreover, provided with a collar 48, having a circumferential groove 50 cut into it, which at one place is interrupted by a stop 49. The front wall of the groove is cut through, as at 51, at a point distant from (as shown nearly diametrically opposite to) the stop 49. To the front end of the spindle a spiral spring 52 is secured. A sleeve 53 is so placed on the front end of the spindle 46 that an inwardly-projecting stud 54 on the inner side and near the front end of the sleeve 53 comes into contact with the front side of the collar 48, and that the sleeve comes into engagement with the free end of the spring 52, Fig. 7, the end of the spring 52 being bent, as at 52<sup>a</sup>, and inserted in a recess in the sleeve 53. (See Fig. 9.) The sleeve is then turned around the spindle in the direction of the arrow, Fig. 7, whereby the spring is put under tension until the stud 54 comes opposite the opening 51 in the front wall of the groove 50, and then the spindle is forced into the sleeve until the stud has fully entered the groove. The spring being under tension then turns the sleeve around the spindle in a direction opposite to that indicated by the arrow in Fig. 7 until the stud 54 strikes against the stop 49 in the groove 50, as shown in Figs. 8, 8<sup>a</sup>, and 9. As the sleeve in this latter movement does not turn through the whole angle through which it has been turned in the direction of the arrow, Fig. 7, the spring 52 has in the position of the parts shown in Figs. 8 and 9 a certain initial tension and holds the stud 54 against the stop 49 with a force which may be varied by properly selecting the angular distance between the opening 51 and the stud 54 in the position of the parts shown in Fig. 7. The spindle and the sleeve are then so firmly connected the one with the other that they may be handled without any risk of accidental separation. The whole is then inserted spindle foremost into the bore at the front end of the drum 42 until the key 47 on the spindle comes against an incline 55 at the front end of its key-groove in the drum, as shown in Fig. 10 in full lines, and a key 57 on the sleeve 53 enters a notch 58 in the inwardly-projecting flange 59 at the front end of the bore in the magazine-drum 42. On then forcing the spindle and the sleeve inward into the bore of the drum the spindle is first turned in the sleeve against the action of the spring 52, the inner end of the key 47 sliding along the incline 55 and the sleeve being prevented from turning in the drum by the key 57 engaging into the notch 58. When the key 47 has entered the key-groove 56, both the sleeve and the spindle move forward in the drum straightly, being guided by the keys 47 and 57 engaging into the key-groove 56 and the notch 58, respectively; but



when finally the key has come completely inside the flange 59 the spring 52 turns the sleeve 53 in the drum, (which is then free to do so, the key 57 having come out of engagement with the notch 58 in the flange 59,) so that the key 57 abuts against a full portion of the flange 59, as indicated in dotted lines in Fig. 10. The drum, the spindle, and the sleeve are then so firmly held together that they may be safely handled.

10 The round journal-pin 43 of the drum is then placed into its bearing 44 on the bottom plate of the magazine-casing, and the projection 60 (the cross-section of which is preferably a flat rectangle) at the free end of the sleeve 53 is pushed from above into a corresponding slot in the standard 61 on the bottom plate of the magazine-casing, so that this sleeve is prevented from turning in the magazine, while the drum 42, together with the spindle 46, are free to turn relatively to sleeve 53.

20 When the cartridges are introduced from above into the magazine, the drum is charged with these cartridges in the manner usual with drum-magazines, being turned together with the spindle 46 in one direction against the action of the spring 52, the tension of the same being increased. The step-by-step rotation of the drum in the opposite direction under the action of the spring causes the cartridges carried by the drum to be raised one by one into the path of the breech-bolt in the well-known manner, and the movement of the drum is stopped after each step, likewise in the well-known manner, the topmost cartridge on the drum coming against a spring-stop (not shown) provided in the breech-casing. When the last cartridge has been taken from the drum and fired and the breech-bolt has made its recoil movement, as above described, the drum is so turned by the spring 52 that a broad wing 75 on the drum comes into the path of the breech-bolt, as indicated in Fig. 8, thus arresting the latter in the open position and indicating to the marksman that the magazine is empty.

45 This arrangement is also well known in guns with drum-magazines. Owing to the initial tension imparted to the spring 52, as above described, the drum raises with certainty even the last cartridge into the path of the breech-bolt.

In order to remove the drum, together with the spindle 46 and the sleeve 53, from the magazine-casing and to separate the spindle from the sleeve, the operations above described have to be repeated in the reverse order.

50 In guns of the kind above described the breech-bolt after having cocked the hammer must continue its rearward motion, remaining in contact with the hammer-head, and owing to the tension of the firing-spring acting upon the hammer there will be a comparatively strong friction between the breech-bolt and the hammer-head. In order to avoid this, the sear is so shaped that after the breech-bolt 7

has passed over the head of the hammer 21 and thus cocked the latter the point 62 of the sear is in front of and bears against a surface 621 at the outer end of the nose 622, constituting the outer wall of the sear-notch 63 of the hammer, as indicated in Fig. 14<sup>a</sup> and in full lines in Fig. 14, the rear arm 27 of the sear being made so long that in this position of the parts its upper end projects beyond the upper edge of the lock-casing into the path of the breech-bolt 7, as indicated in Fig. 14<sup>a</sup> and in dotted lines in Fig. 3. If after cocking the hammer the breech-bolt continues its rearward movement and meeting the upper end of the arm 27 depresses the same into the position shown in full lines in Fig. 3, the point 62 of the sear acting against the surface 621 will at first further cock the hammer until this point is so far raised that it is clear of the surface 621, and then this point will be forced into the notch 63, so that the parts come into the position indicated in dotted lines in Fig. 14 and Fig. 14<sup>b</sup> and the hammer is overcocked as compared with the position imparted to the same by the breech-bolt. By thus overcocking the hammer the head of the same has been brought out of contact with the breech-bolt, as shown in Figs. 3 and 14<sup>b</sup>. The parts are so shaped that in this position the direction of the pressure exerted by the hammer on the point of the sear is practically radial to the fulcrum of the sear, so that the upper end of the rear arm 27 of the sear bears with only slight pressure, and consequently with but little friction, against the breech-bolt. Thus the objectionable friction between the hammer and the breech-bolt is completely obviated and the friction between the breech-bolt and the sear-arm 27 is reduced to a minimum.

A lever 89 is pivoted at 91 to the trigger 85, fulcrumed at 92, and its hook-shaped front end is held upward by a spring 86, so as to engage the projecting bottom end of the rear arm 27 of the sear when the hammer is fully cocked and the point 62 of the sear has entered the notch 63, as shown in Fig. 3. 87 is the sear-spring, interposed between the trigger and the rear end of the sear. On pulling the trigger the hook-shaped end of the lever 89, engaging the rear end of the sear, causes the latter to be turned around its trunnions in such a direction as to draw out the point 62 from the notch, as will be evident from Fig. 3. During the first part of this movement the point 62 of the sear slides along the inner side of the nose 622, camming the same slightly downward and preventing the hammer from striking; but when the sear has been turned so far by the trigger 85 and the lever 89 that its point 62 has come clear of the surface 621 the hammer is released and strikes under the action of the firing-spring 65, rounded flanges 88 on the outer side of the nose 622 sliding over the point 62, as shown

in Fig. 1. This trigger mechanism does not, however, constitute a part of the present invention.

The sear as a whole forms a frame, the rear arm 27 being carried by two arms 66, Fig. 11, starting from the trunnions 64 67, constituting the fulcrum of the sear, and the point 62 being carried by arms 68, likewise starting from the trunnions, so that the hammer may freely move on cocking or striking in the open space between the pairs of arms 66 and 68 and the trunnions 64 and 67. This construction of the sear permits to give the fulcrum of the same the most favorable position relatively to the fulcrum 69 of the hammer without in any way interfering with the movements of the hammer.

In order to prevent at will the gun from being fired, a safety device is provided which acts to so lock in position the sear that its point 62 cannot be withdrawn from the notch 63. This safety device consists of an elastic arm 70, having a circular head 71 projecting laterally at one end thereof, as shown in Figs. 17 and 17<sup>a</sup>, and having a projection 73 at the face remotest from the arm 70. This head is inserted laterally into the lock-casing through a circular hole 72, having a lateral enlargement 78 in the side wall 90 of the lock-casing, the hole 72 fitting the head 71 and the enlargement 78 the projection 73. By then turning the arm 70 the projection 73 on the head 71 is caused to locate itself behind the circular part of the edge of the hole 72, the same as in a so-called "bayonet-joint," so that the head 71 cannot be drawn out laterally from the lock-casing, Figs. 12 and 18. This head is provided with a central recess 74, the wall of which is cut through at one point, as at 741. On the side of the sear-point 62 adjacent to the head 71 there is provided a tooth 76, Figs. 3, 12, 18, 19, and 20.

In the position of the parts shown in full lines in Fig. 12 (when the arm 70 is in the position marked I) the tooth 76 is opposite the opening 741, and when the sear is then actuated by pulling the trigger, as hereinbefore described, this tooth will enter through this opening into the recess 74. The width of this recess and the length of the tooth 76 are so determined that when the tooth has fully entered this recess the point 62 of the sear has been completely withdrawn from the notch 63 and has come clear of the surface 621 and the hammer is free to strike. When, however, the arm 70 is turned into the position marked II in Fig. 12, the tooth 76 is opposite a full portion of the head 71, as shown in Fig. 20, so that it cannot enter the recess 74. Consequently in this position of the arm 70 and head 71 the point 62 of the sear cannot be withdrawn from the notch 63, and the gun cannot be fired. By turning the lever 70 into the position marked III in Fig. 12 the projection 73 of the head 71 is brought in

front of the enlargement 78 of the hole 72 of the lock-casing, so that the head may be drawn out laterally from this casing. The arm 70 is held in the positions I and II by engaging into suitable notches on the lock-casing. After the arm 70 and the head 71 have been removed in this way and after the removal of the trigger and parts connected thereto the sear may be turned into the position shown in Fig. 21 and in dotted lines in Fig. 12, and then the hammer 21 may be drawn out from the lock-casing between the arms 66 68 and the trunnions 64 67, the firing-spring 65 and the journal-stud 69 of the hammer having been previously removed.

The trunnion 67 is not completely surrounded by its bearing 80 in the wall of the lock-casing, but only over an angle of something more than one hundred and eighty degrees, as seen in Figs. 12 and 21. The remaining part of the circumference of this trunnion projects freely beyond the edge of the lock-casing. Moreover, a part of the circumference of the trunnion 67, which is slightly greater than that left uncovered by the bearing 80, projects beyond the upper edge of arms 66 68, as shown in Figs. 12 and 21. If, therefore, after the removal of the hammer the sear is turned into the position shown in Fig. 21 and in dotted lines in Fig. 12, in which the part of the circumference of the trunnion 67, on which it is connected with the arms 66 68, is outside the bearing 80, the sear may be pushed out laterally from the lock-casing, as shown in dotted lines in Fig. 11, the corresponding side wall of the lock-casing (in Figs. 12 and 21 the front one) being suitably cut out for this purpose, as at 79, until the trunnions 64 67 have come out of their bearings in the side walls of the lock-casing, and the sear is then entirely free to be taken out from the lock-casing.

The insertion of the sear and the hammer into the lock-casing is effected by repeating the operations above described in reverse order. After inserting the head 71 of the arm 70 into the lock-casing the sear is prevented from being turned into the position shown in Fig. 21 and in dotted lines in Fig. 12, its movement being stopped by such head, so that this head also serves to hold in position the sear in the lock-casing.

In order to enable this automatic gun to be used as a single-loader—that is to say, to be charged separately with a single cartridge for each shot at the right side of the breech-casing—a spring-catch 81, Figs. 13 and 13<sup>a</sup>, is pivoted, provided at its front end with a projection 82, reaching into the path of the breech-bolt. In the recoil movement of the breech-bolt this projection is forced back by the incline 83 at the rear end of the right-hand guide-rib 33 of the breech-bolt, but then moves inward again, so as to come in front of the shoulder 84 at the front end of this guide-

rib. The inclination of the rear side of the projection 82 is so selected that if the breech-bolt is moved forward rapidly and vigorously, as in the case when it is thrown forward by its spring 6, the shoulder 84 moves past the rear side of the projection 82 without being caught thereby, but that if the breech-bolt is moved forward slowly the shoulder 84 is sufficiently firmly engaged by the rear side of the projection 82 to arrest the forward movement of the breech-bolt. If the gun has to be used as a single-loader, the magazine-drum being emptied, the breech-bolt is moved back by hand until it comes into engagement with the projection 82 and is arrested thereby, then a cartridge is put by hand on the broad wing 75 of the magazine-drum 42, which wing is thereby turned down so far as not to be in the way of the breech-bolt, and, finally the spring-catch 81 is depressed, so that the breech-bolt is released and on being thrown forward by its spring 6 pushes the cartridge into the barrel, closes the breech, and is locked by the tumbler locking-bolt 8. After firing the breech-bolt is thrown back by the recoil and immediately afterward thrown forward by its spring 6, but is arrested by the wing 75 of the magazine-drum, as above explained. Then the breech-bolt may be moved back again until it is engaged by the projection 82 and a fresh cartridge placed on the wing 75, and so on, as just described.

What is claimed is—

1. In a small-arm the combination of a frame fixed to the butt, a barrel and a breech-casing secured to the barrel and adapted to slide longitudinally in the said frame, a spring interposed between the frame and the breech-casing, a breech-bolt adapted to slide longitudinally in the breech-casing, means for locking the breech-bolt in its breech-closing position, a rear head-plate on the breech-casing, a guide-bolt adapted to engage into a hole in the rear head-plate and a spring interposed between the breech-bolt and the guide-bolt, with a cap, a rear head-plate on such cap adapted to overlap the rear head-plate of the breech-casing, a hole in the rear head-plate of the cap adapted to receive the rear end of the guide-bolt, such rear end of the guide-bolt being forced into the said hole in the rear head-plate of the cap by the said spring interposed between the breech-bolt and the rear head-plate of the breech-casing a projection or projections on the front end of the cap and a recess or recesses in the breech-casing adapted to engage with such projection or projections substantially as and for the purpose described.

2. In a small-arm the combination of a frame fixed to the butt, a barrel and a breech-casing secured to the barrel and adapted to slide longitudinally in the said frame, a spring interposed between the frame and the breech-casing, a breech-bolt adapted to slide longitudinally in the breech-casing, means for locking

the breech-bolt in its breech-closing position, a rear head-plate on the breech-casing, a guide-bolt adapted to engage into a hole in the rear head-plate and a spring interposed between the breech-bolt and the guide-bolt with guide-ribs at the sides of the breech-bolt, guide-ribs at the inner side of the side walls of the breech-casing ending at a distance from the rear head-plate of the breech-casing, the guide-ribs on the breech-bolt being adapted to slip and be guided under the guide-ribs on the breech-casing substantially as and for the purpose described.

3. In a small-arm the combination of a frame fixed to the butt, a lock-casing fixed in such frame, a barrel and a breech-casing secured to the barrel and adapted to slide longitudinally in the frame, a spring interposed between the fixed frame and the breech-casing, a breech-bolt adapted to slide longitudinally in the breech-casing, a spring interposed between the breech-bolt and the rear head-plate of the breech-casing and means for locking the breech-bolt in its breech-closing position with a firing-pin adapted to slide longitudinally in the breech-bolt, a recess on the under side of the firing-pin, an incline forming the rear wall of such recess, a locking-dog pivoted at its front end in the breech-bolt and adapted to snugly fit the recess in the firing-pin and to have at the same time its under side flush with the under side of the breech-bolt, a recess in a bridge-piece in the lock-casing opposite to the rear end of the locking-dog at the closed position of the breech-bolt an incline at the rear end of the said recess in the bridge-piece and means for throwing forward the firing-pin substantially as and for the purpose described.

4. In a small-arm the combination of a breech-bolt with a firing-pin adapted to slide longitudinally in the breech-bolt a recess on the under side of the firing-pin an incline forming the rear wall of such recess, a locking-dog adapted to snugly fit the recess in the firing-pin and to have at the same time its under side flush with the under side of the breech-bolt, lateral trunnions at the front end of the locking-dog, a recess at the under side of the breech-bolt adapted to receive the locking-dog, an enlargement at the rear end of the recess in the breech-bolt and grooves in the sides of the recess in the breech-bolt extending from such enlargement to the front end of this recess and adapted to receive the trunnions on the locking-dog, substantially as and for the purpose described.

5. The combination with the breech-casing, of a breech-bolt adapted to slide longitudinally therein, a hammer pivoted below such breech-casing and adapted to be engaged and turned by the said breech-bolt to a predetermined position, a notch in the hammer, a nose constituting the outer wall of such notch, a surface at the outer end of such nose, a sear pivoted

below the breech-casing, a point on such sear adapted to bear against the surface at the outer end of the said nose at the aforesaid predetermined position of the hammer, a rear arm on the sear adapted to project into the path of the breech-bolt at the aforesaid predetermined position of the hammer and means for withdrawing the point of the sear from the notch in the hammer substantially as and for the purpose described.

6. The combination with a lock-casing for small-arms the sear-point, the rear arm of the sear, arms connecting the sear-point with the rear arm of the sear, on either side, trunnions on the outer side of such connecting-arms, one of these trunnions having part of its circumference projecting freely beyond its connecting-arms, a bearing in the lock-casing for this latter trunnion surrounding a part of the circumference of the same only which is smaller than the part of this circumference projecting from the connecting-arms, a cut-out in the side of the lock-casing containing the last-named trunnion-bearing and a bearing for the other trunnion on the other side of the lock-casing.

7. In a lock for small-arms the combination of a sear-point, a rear arm of the sear, arms connecting the said rear arm of the sear with its point on either side, trunnions on the outside of such connecting-arms and bearings for such trunnions in the lock-casing with a ro-

tatable head projecting into the lock-casing, a recess in such head and a tooth on the side of the sear adjacent to such head and adapted to enter into such recess at a predetermined position only of the head substantially as and for the purpose described.

8. In a small-arm the combination of a frame fixed to the butt, a barrel and a breech-casing secured to the barrel and adapted to slide longitudinally in the frame, a spring interposed between the fixed frame and the breech-casing a breech-bolt adapted to slide longitudinally in the breech-casing, a spring interposed between the breech-bolt and the rear head-plate of the breech-casing and means for locking the breech-bolt in its breech-closing position with a guide-rib on the breech-bolt, a spring-catch pivoted at one side of the breech-casing, a projection on the front end of the catch adapted to enter into the path of such guide-rib, an incline at the rear end and a shoulder at the front end of the guide-rib substantially as and for the purpose described.

In testimony whereof I affix my signature in presence of two witnesses.

CÄCILIE VON MANNLICHER,  
*Administratrix of the estate of Ferdinand  
von Mannlicher, deceased.*

Witnesses:

I. GEO. HARDY,  
MAX HOFINGER.